

Posa

ARMCHAIRS

2008

David Chipperfield



Description

For this project Chipperfield was particularly concerned with finding versatile, robust seating which would meet rigorous usage requirements while conveying a sense of refined luxury. It is planned to finish the museum seating in leather. This line of research has been combined with another theme that Chipperfield was keen to explore; that of obtaining comfortable soft seating from thin upholstered sections applied to a light and dynamic structure, using advanced industrial production techniques.

Technical information

Internal frame

tubular steel and steel profiles

Internal frame upholstery

Bayfit® flexible cold shaped polyurethane foam, polyester fibre cover

Lower edge

aluminium

Wheels (PO62W)

plastic material

Ferrules

thermoplastic material

Cover

fabric or leather in limited categories

Technical drawings

PO62

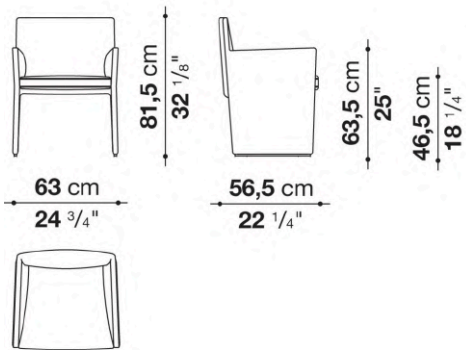

PO62W

