

Shelf

LIVING STORAGE UNITS

2006

Naoto Fukasawa



Description

Homogeneous white Corian®, thin surfaces and strong geometrical features make the bookcases Shelf exclusive items, important presences that are also almost immaterial. Available in four sizes, of which one is designed for wall mounting. The other three can be placed even at the centre of the room as partition or screen.

Technical information

Frame

DuPont™ Corian® (acrylic material)

Wall fixing brackets (SL180)

galvanized steel profiles

Technical drawings

SL66

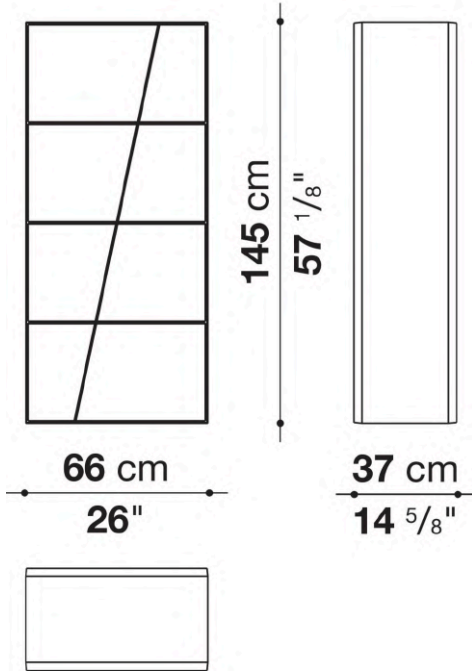

SL66_1

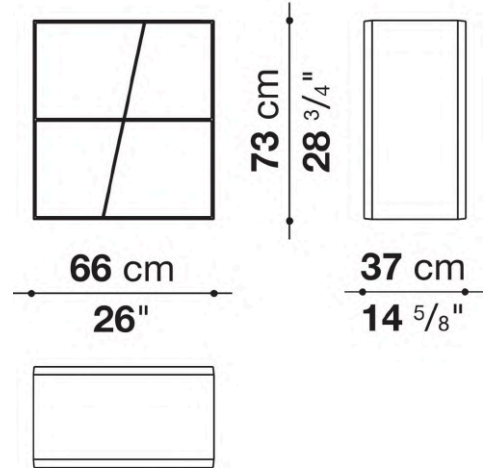

SL96

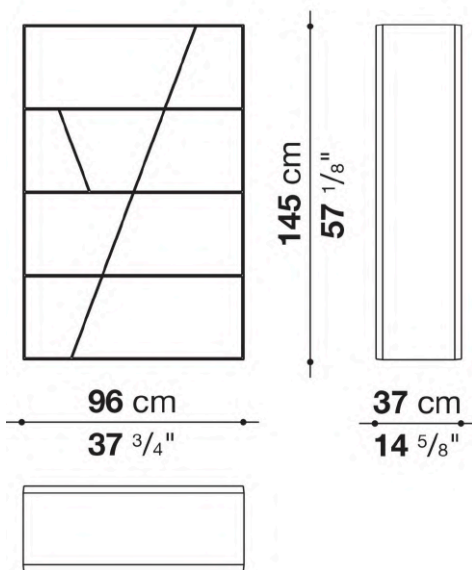

SL180

