

# Ac Executive

LIVING STORAGE UNITS

2007

Antonio Citterio



## Description

---

A complete range of wooden furniture designed to furnish executive offices and meeting rooms with great elegance, but also to solve home office needs. The series includes storage units, sideboards, bookcases, meeting tables and writing-desks. There are also solutions for wiring management, storage units with lockable drawers for suspended filing and wardrobe use containers.

## Technical information

---

**Frame (ACE1)**

veneered honeycomb-core and wood particles panel

**Frame (ACE3C)**

solid wood, veneered wood particles panel

**Frame (ACE8-ACE5-ACE4-ACE17-ACE22)**

solid wood, wood particles panel, veneered honeycomb-core and wood particles panel

**Back panel (ACE3C)**

veneered wood particles panel, glass or fabric

**Drawer (ACE1-ACE4-ACE5-ACE8)**

wood particles panel, multi-layered wood panel

**File holder support (ACE1-ACE4-ACE5-ACE8)**

drawn steel and steel profiles

**Partitions**

methacrylate with aluminium profiles

**Base-frame**

drawn steel

**Adjustable feet**

steel and plastic material

# Technical drawings

## ACE8

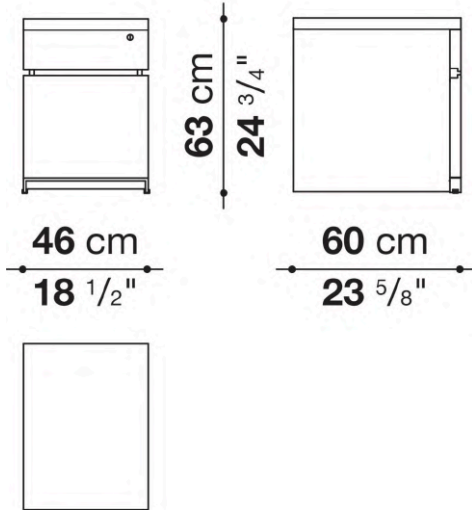

## ACE5

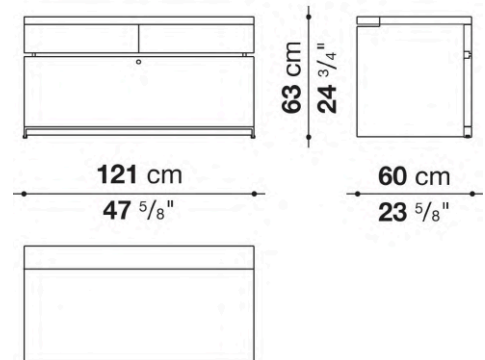

## ACE4S

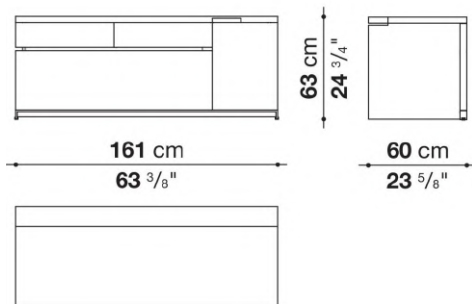

## ACE4D

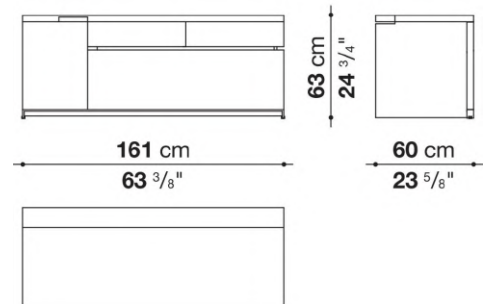

### ACE17

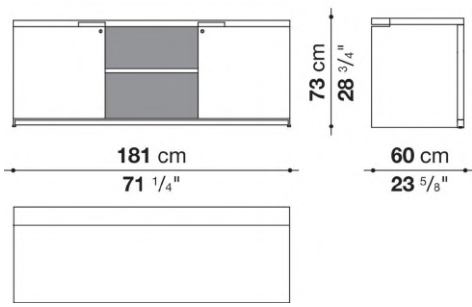

### ACE22

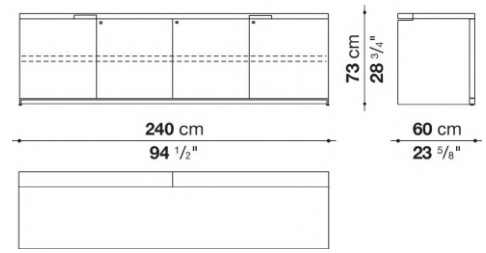

**ACE1**

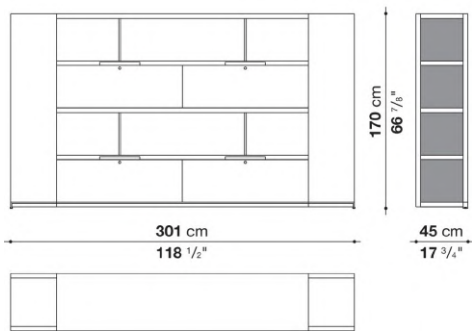

**ACE3C**

