

Richard

SOFAS

2016

Antonio Citterio



Description

The Richard seating system stands out for its balanced and contemporary design, evocative of classic atmospheres. Its modularity is reflected by the presence of several elements, all in two depths: one for more formal and contained solutions, and the other for larger, more informal compositions. The system's extreme flexibility and the ease with which the different elements can be assembled together allows the living space to be interpreted in the most varied configurations, from formal to more relaxed, with seats, benches, ottomans and chaise longues. The wide range of covers, in fabric with matching tone-on-tone or contrasting textile profiles, or in leather with profiles in the same material, allows for even greater customisation, offering monochromatic or contrasting solutions. The frame is underscored at the base by a metal profile. Optional cushions in various sizes add to the overall comfort.

Technical information

Internal frame

tubular steel and steel profiles

Internal frame upholstery

Bayfit® flexible cold shaped polyurethane foam, polyester fibre

Seat cushion upholstery

shaped polyurethane of different density, visco-elastic polyurethane, sterilized down, polyester fibre

Back cushion upholstery

polyester fibre, shaped polyurethane, sterilized down

Lower edge

die-cast aluminium and extrusions

Ferrules

thermoplastic material

Cover

fabric (profiles in Bellano or Bormio fabric) or leather

Technical drawings

9RA230

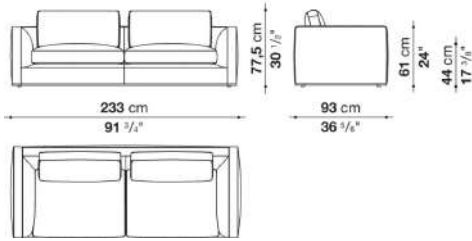

9RA260

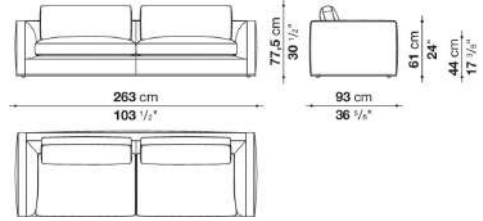

9RA280

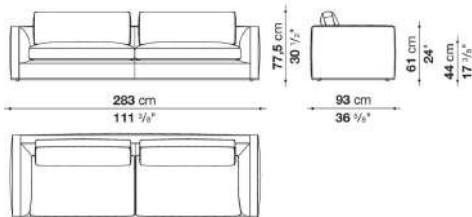

9RA85C

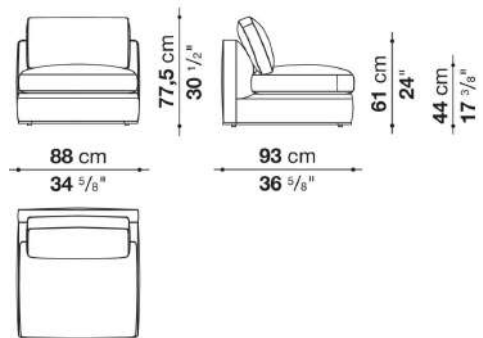

9RA100C

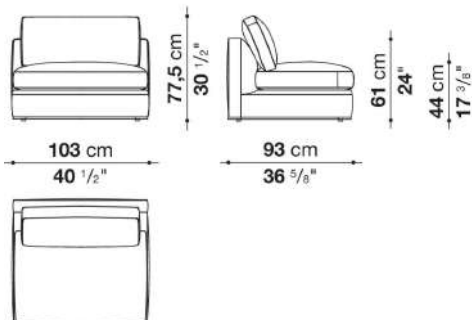

9RA190C

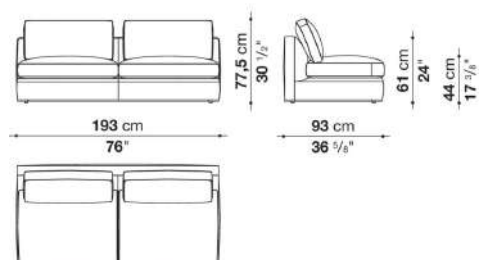

9RA220C

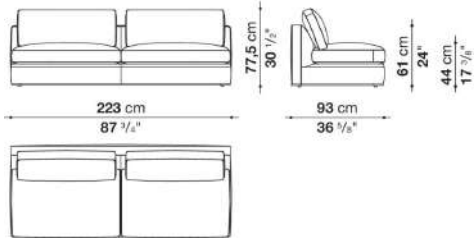

9RA240C

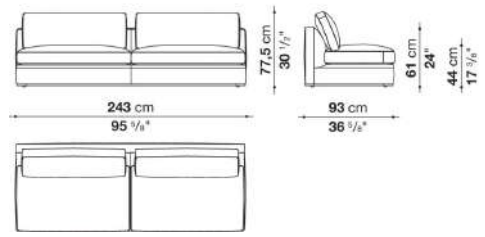

9RA105TS

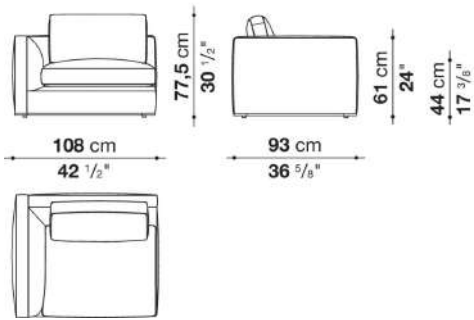

9RA105TD

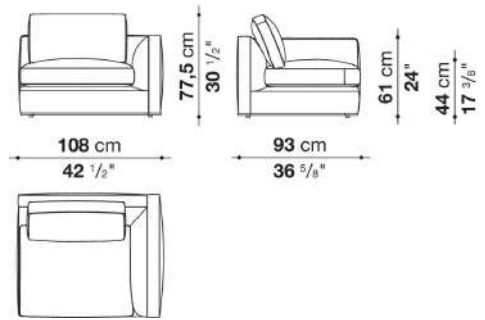

9RA120TS

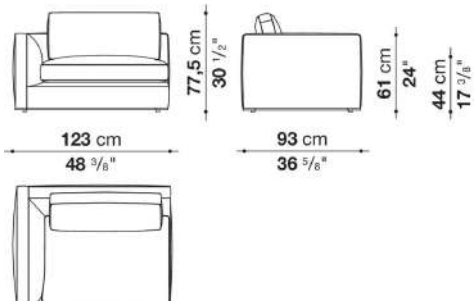

9RA120TD

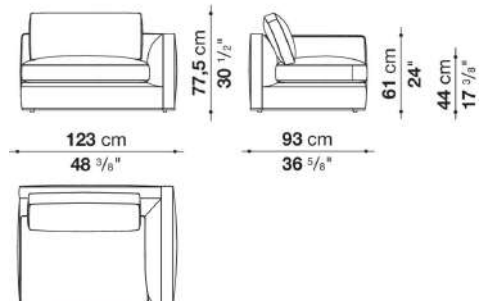

9RA210TS

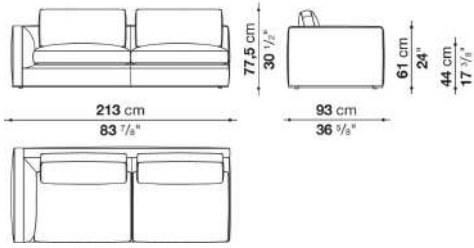

9RA210TD

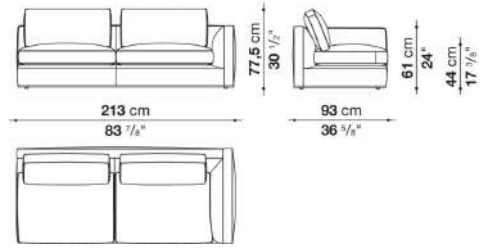

9RA240TS

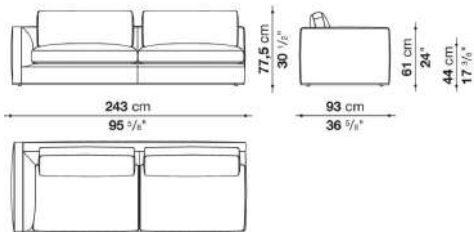

9RA240TD

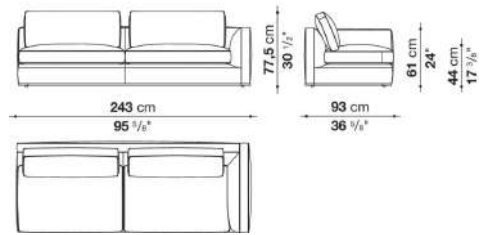

9RA260TS

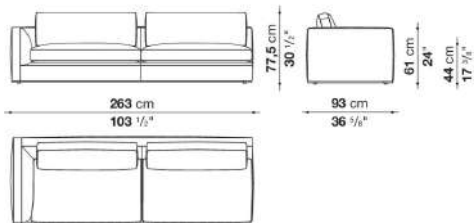

9RA260TD

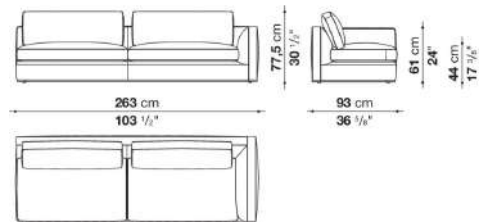

9RA190PS

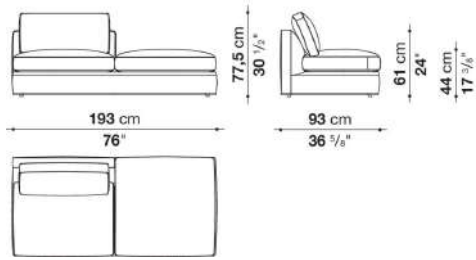

9RA190PD

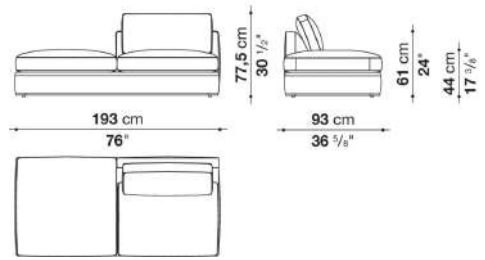

9RA220PS

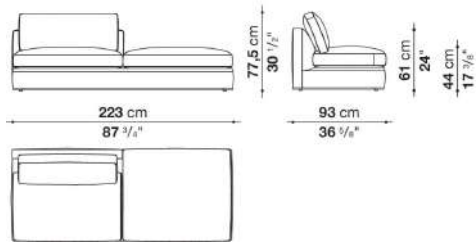

9RA220PD

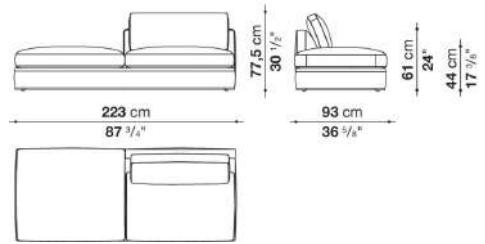

9RA240PS

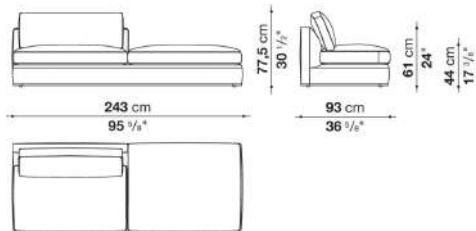

9RA240PD

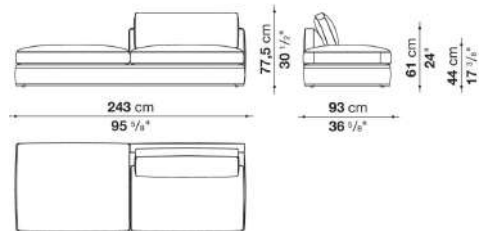

9RA210TPS

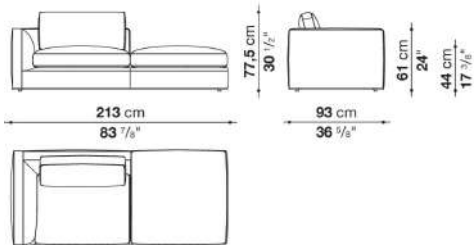

9RA210TPD

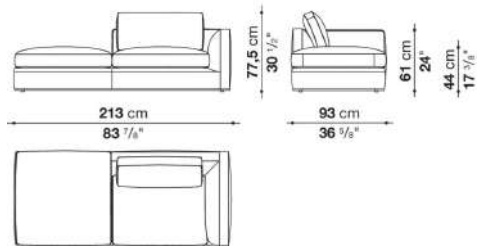

9RA240TPS

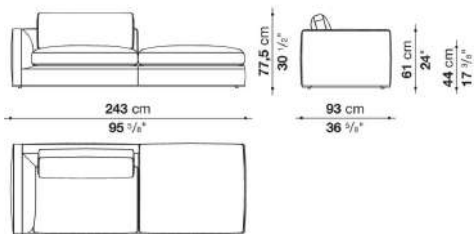

9RA240TPD

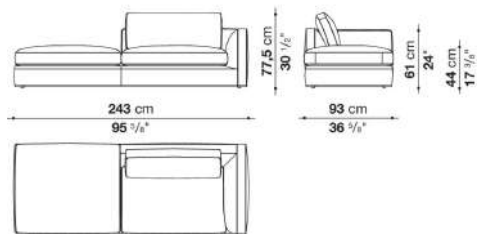

9RA260TPS

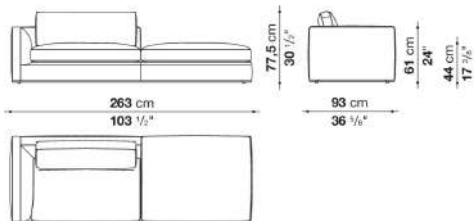

9RA260TPD

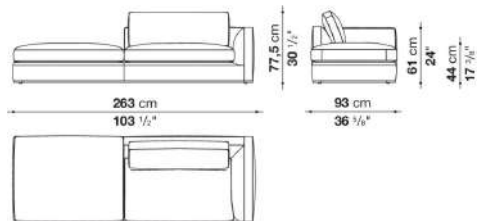

9RA210LS

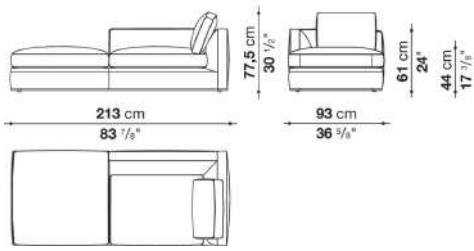

9RA210LD

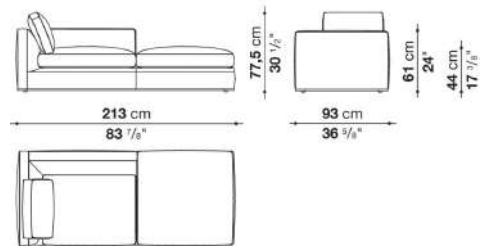

9RA240LS

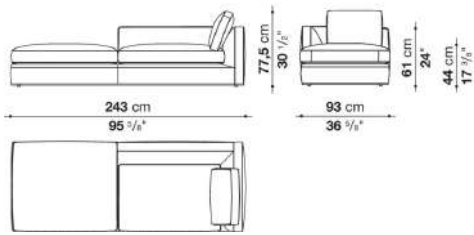

9RA240LD

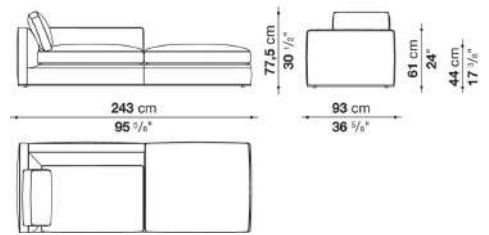

9RA260LS

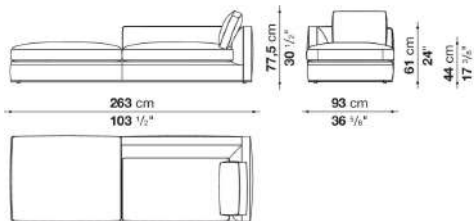

9RA260LD

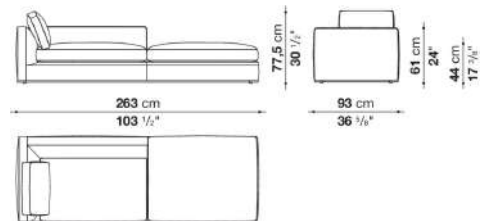

9RA85P

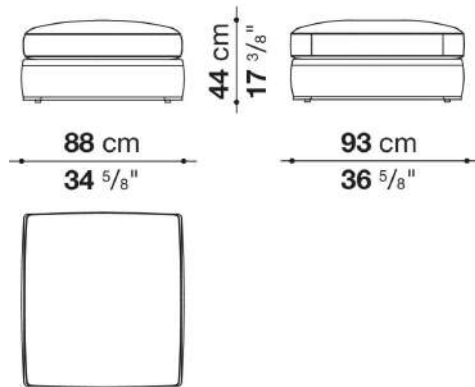

9RA100P

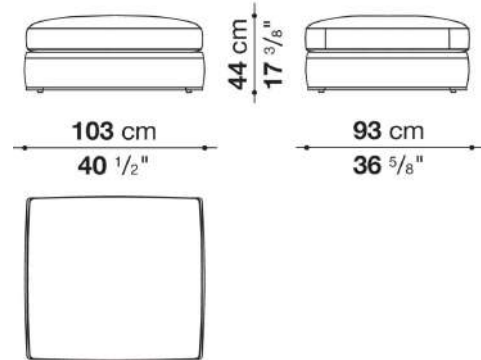

9RA190P

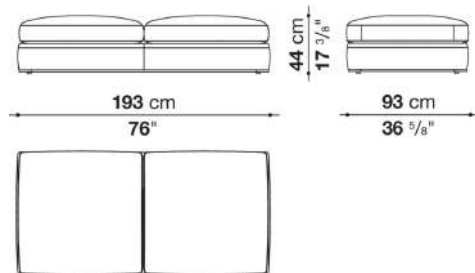

9RA220P

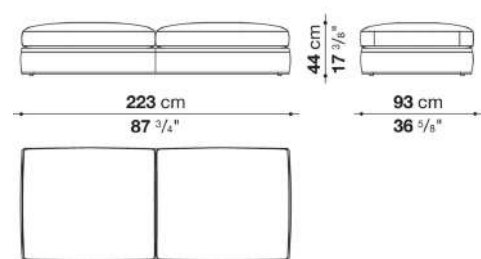

9RA240P

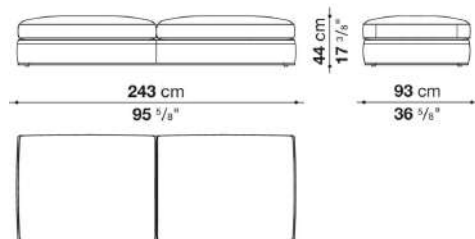

RA90TS

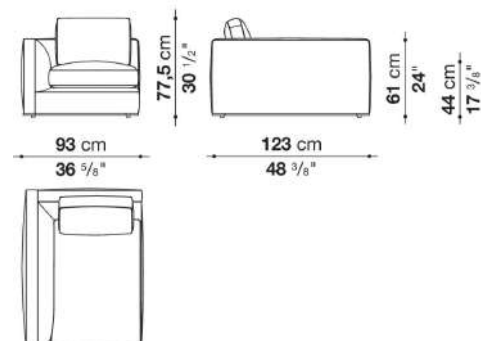

RA90TD

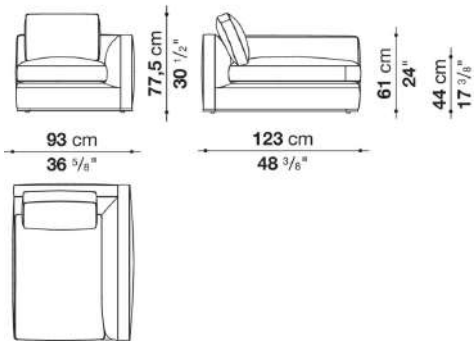

RA85C

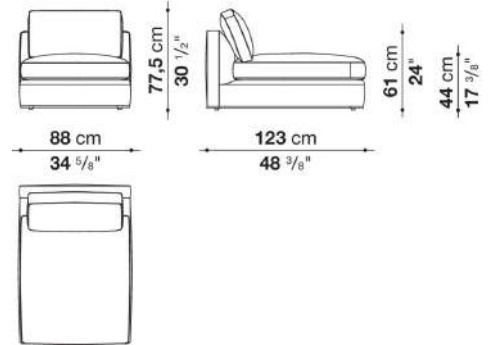

RA260TS

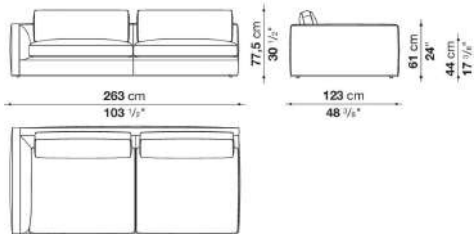

RA260TPS

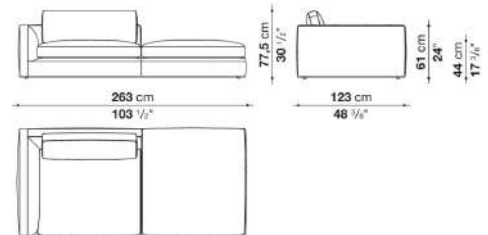

RA260TPD

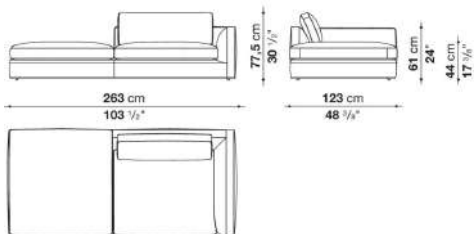

RA260LS

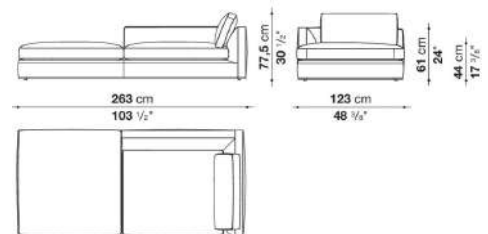

RA260LD

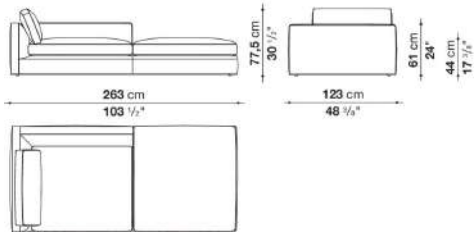

RA260TD

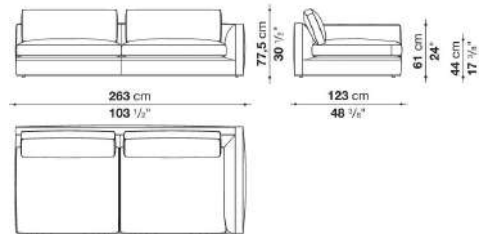

RA240TS

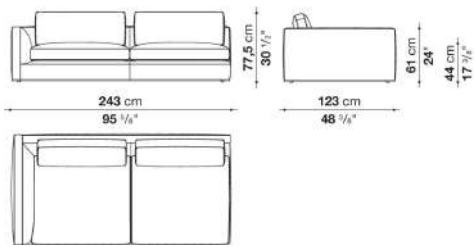

RA240TPS

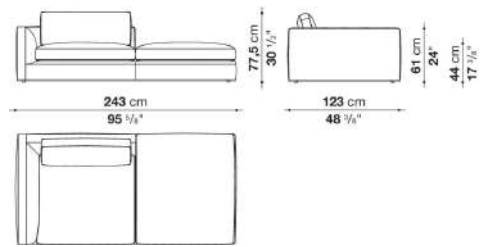

RA240TPD

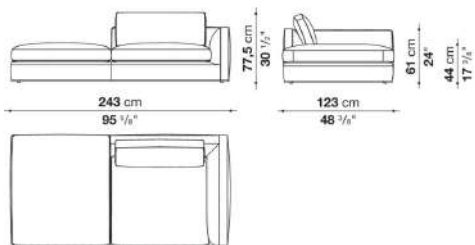

RA240TD

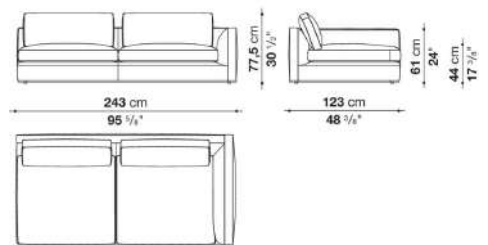

RA240PS

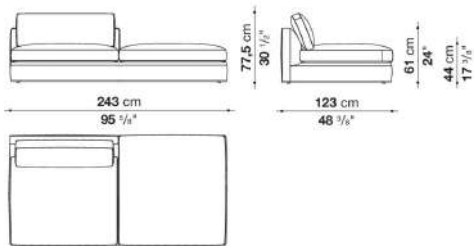

RA240PD

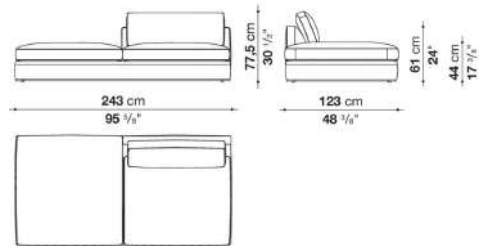

RA240LS

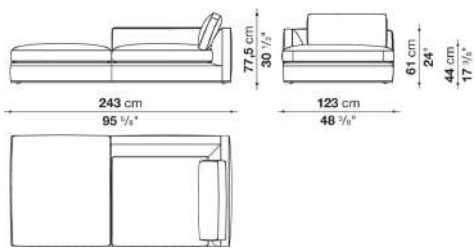

RA240LD

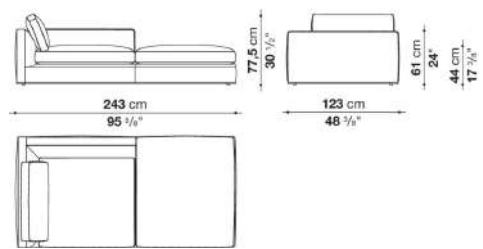

RA240C

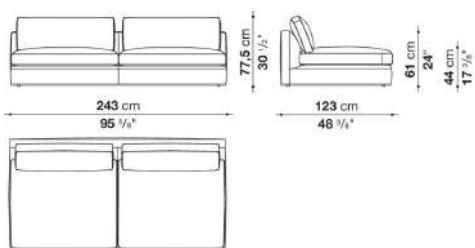

RA220PS

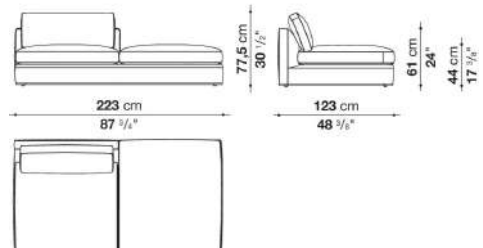

RA220PD

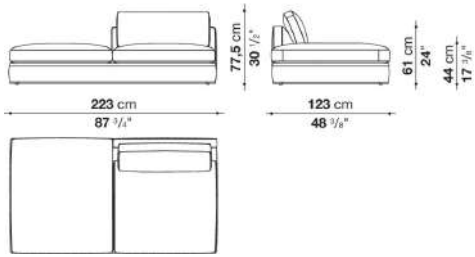

RA220C

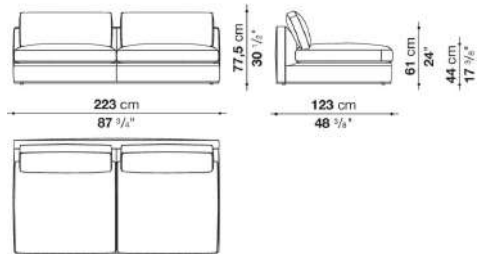

RA210TS

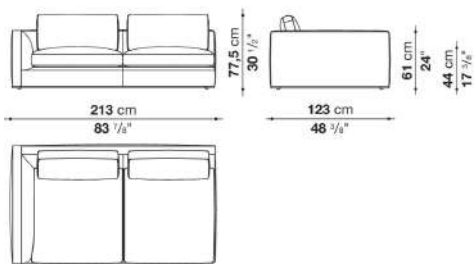

RA210TPS

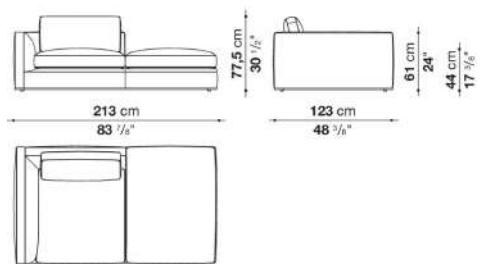

RA210TPD

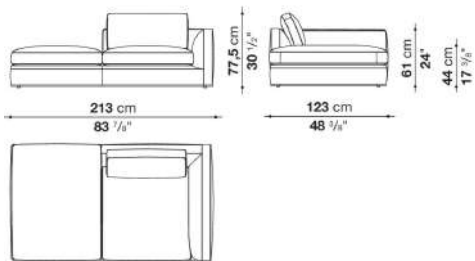

RA210TD

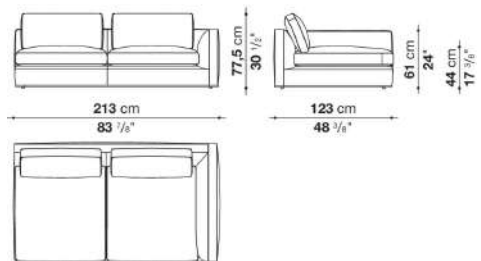

RA210LD

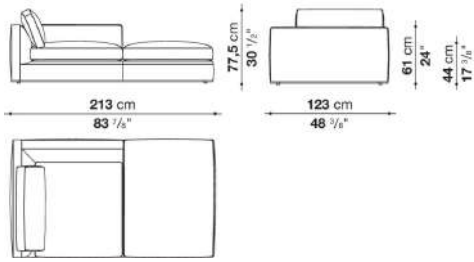

RA190PS

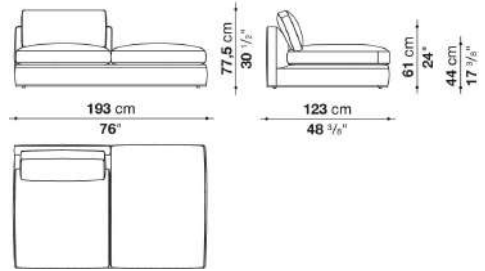

RA210LS

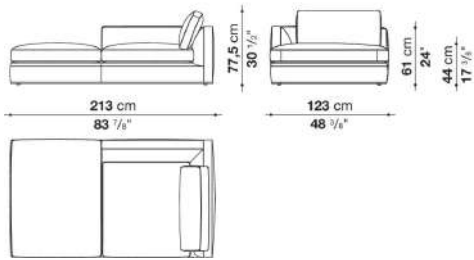

RA190PD

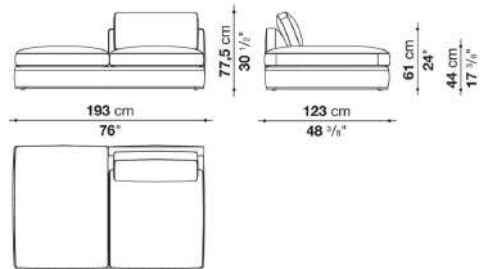

RA190C

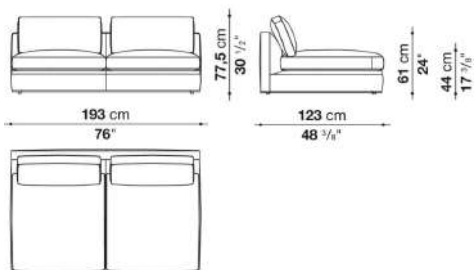

RA120TS

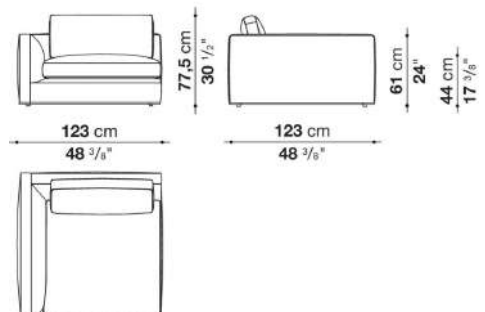

RA120TD

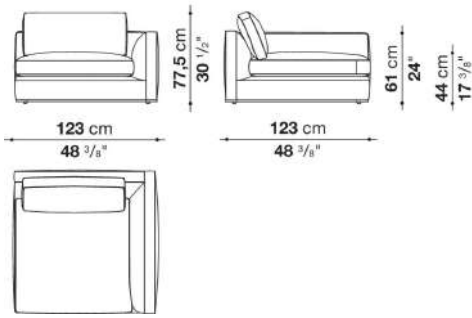

RA105TS

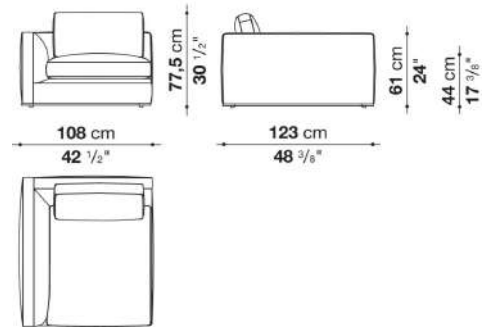

RA105TD

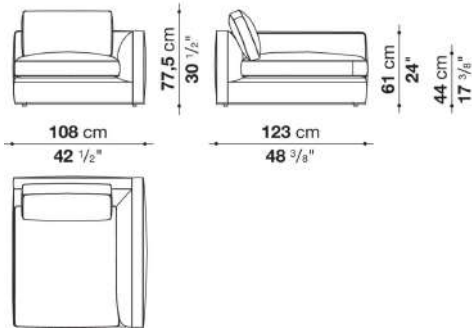

RA100C

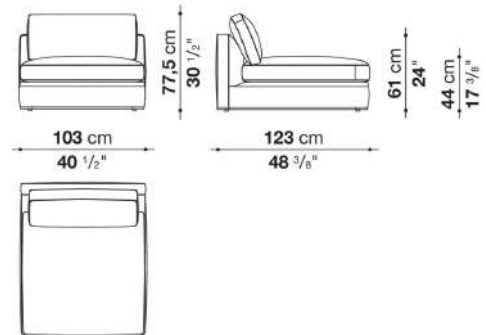

RA85P

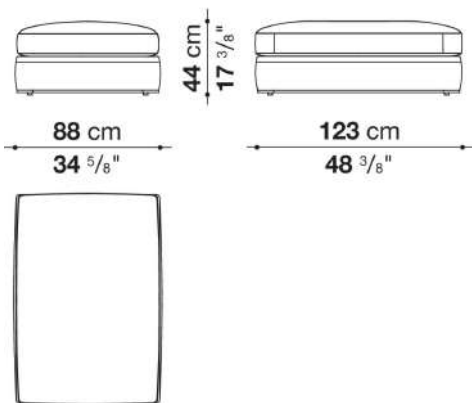

RA240P

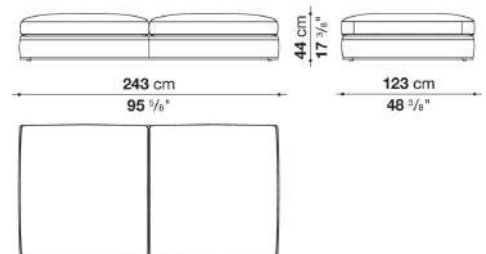

RA220P

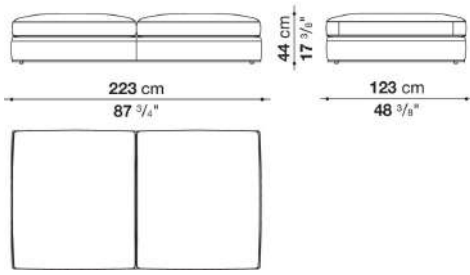

RA190P

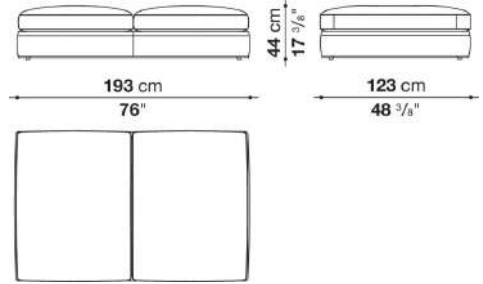

RA100P

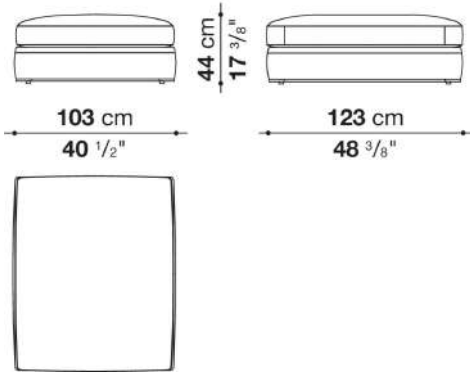

RA280

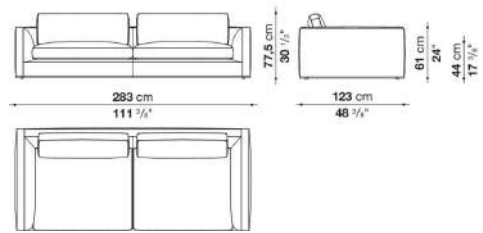

RA260

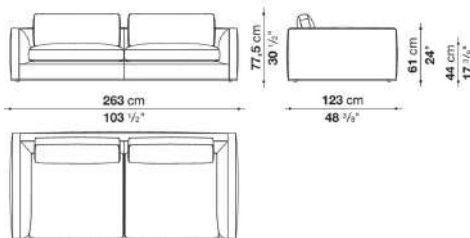

RA230

