Almora

ARMCHAIRS

2014

Nipa Doshi & Jonathan Levien



Description

Almora is a revolving chair named after the Indian region that offers a breath-taking view of the Himalayas and, quoting its designers, it longs to be “a haven from the world, a place for contemplation and reading from where one can admire magnificent snow-capped peaks. As protective as a second skin, enveloping like a soft blanket”. Dedicated to relaxation, it is composed of two conical glass fibre shells: that of the seat resting directly on the base and that of the backrest. The headrest, in curved wood in different finishes, has a padded portion and fits into the back shell, appearing at the same time slightly detached. Almora is an armchair that stands out for the balanced composition of the different elements, the materials and the leather upholstery. The coordinated footrest completes the proposal.

Technical information

Seat, back and headrest internal shell

thermoformed **ABS**

Internal shell upholstery

Bayfit® flexible cold shaped polyurethane foam

Seat and back external shell

glass fibre

Headrest external shell

veneered wood multi-layered panel

Shell fixing to upholstery

clip in plastic material

Support frame

aluminium

Ferrules

thermoplastic material

Cover

leather

Headrest cover (AP106A)

merino

Technical drawings

AP106

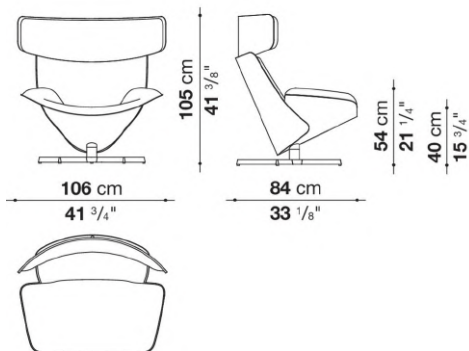

AP106A

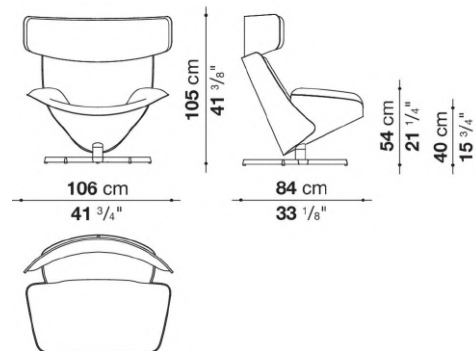

AP76

