



carlton a design stefano conficconi 2018

Modular sofa with a metal seat structure and a seat supported by elastic belts. The seat mat lies on a 3 different density polyurethane foams, which consists of a 3-layered quilted cover with an undeformable foam insert. The armrests are made of wood covered in hypoallergenic goose feathers and polyurethane foam. The wooden backrests are equipped with a mechanism that allows 2 comfort positions with 2 seat depths. The backrest cushions and headrest are in polyurethane foam. The legs are available in painted metal with a bronze effect or painted in matt anthracite with a soft touch finish.

Divano modulare con struttura in metallo, con supporto di nastri elastici. Il materassino di seduta poggia su uno strato di poliuretano espanso a 3 densità ed è formato da un doppio strato di falda trapuntata con anima in gomma indeformabile. I braccioli sono in legno rivestiti in piuma d'oca anallergica ed in poliuretano. Gli schienali in legno sono dotati di un meccanismo che consente 2 posizioni di confort con 2 profondità di seduta. I cuscini degli schienali ed i poggiatesta sono in poliuretano espanso. I piedi sono disponibili in metallo verniciato effetto bronzo o verniciati antracite opaco finizione Soft touch.

seat height altezza seduta	seat depth profondità seduta	arm width larghezza braccio	arm height altezza braccio	feet height altezza piede
43 cm 16.9"	57/81 cm 22.4/31.9"	35 cm 13.8"	57 cm 22.4"	14 cm 5.5"

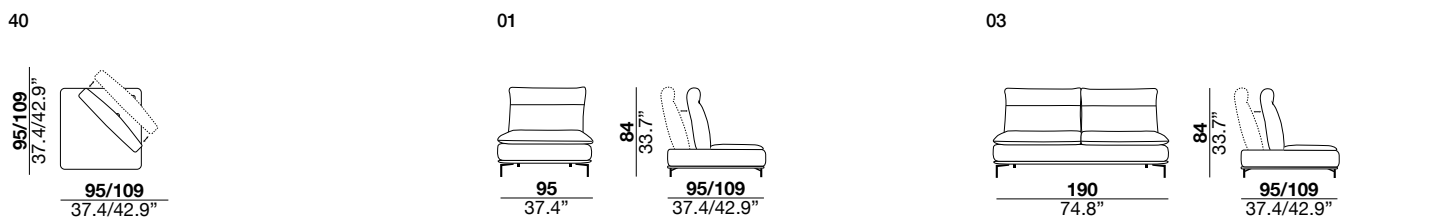
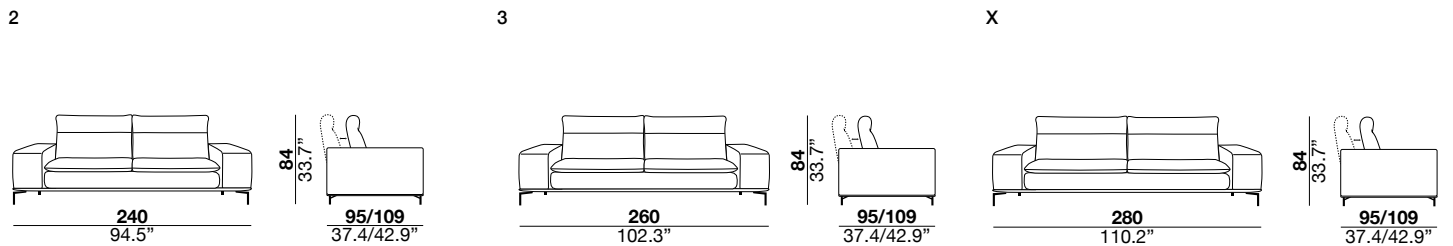
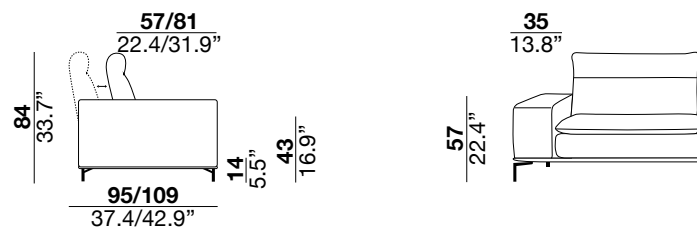

07/08

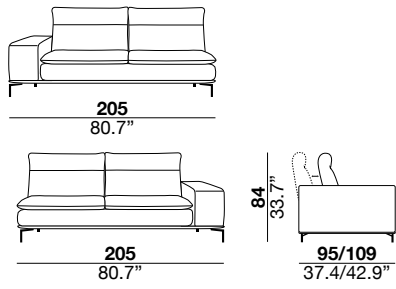

19/20

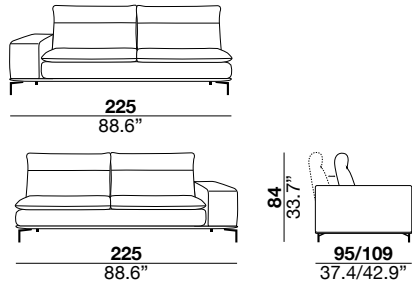

29/30

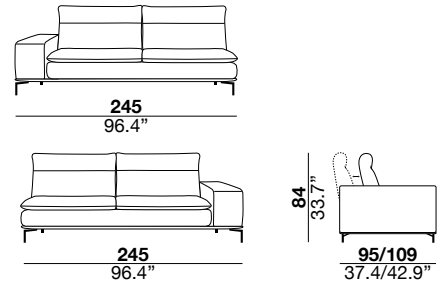

37/38

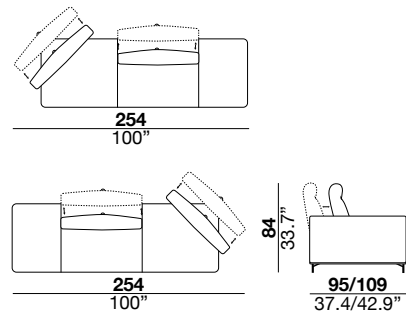

17/18

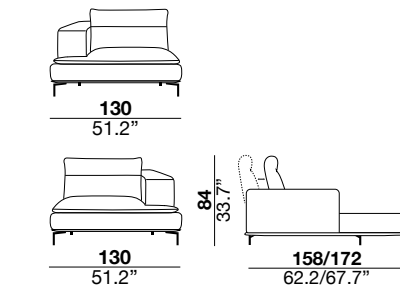

75/76

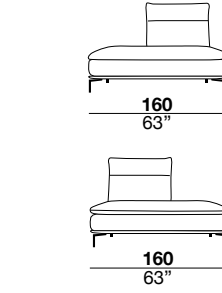

PRT

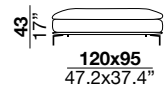

PQU

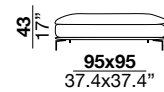

07+18

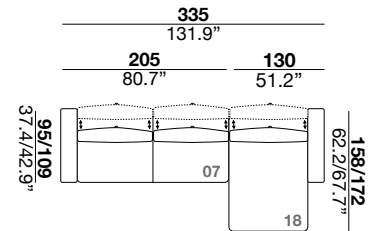

19+18

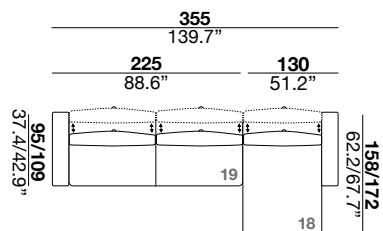

29+18

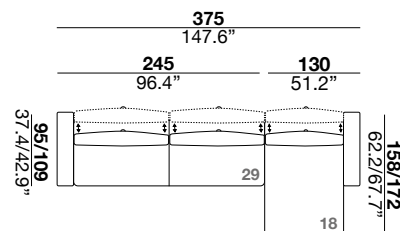

29+37

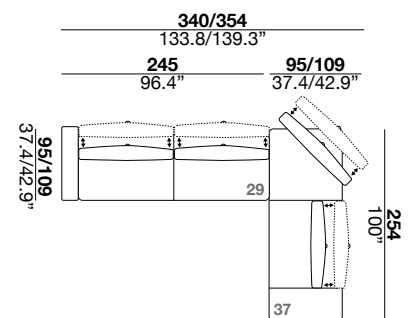

19+37

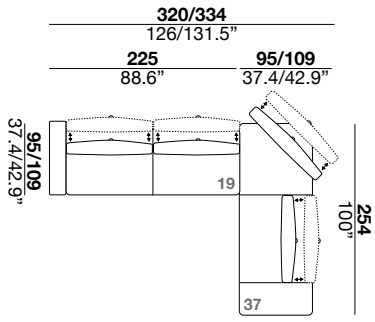

29+40+30

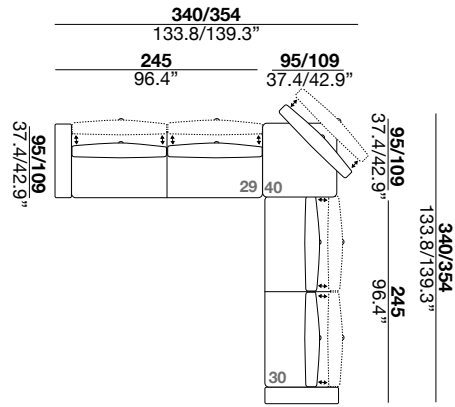

17+03+18

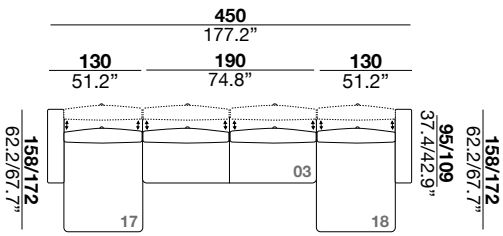



carlton b design stefano conficconi 2018

Modular sofa with a metal seat structure and a seat supported by elastic belts. The seat mat lies on a 3 different density polyurethane foams, which consists of a 3-layered quilted cover with an undeformable foam insert. The armrests are made of wood covered in hypoallergenic goose feathers and polyurethane foam. The wooden backrests are equipped with a mechanism that allows 2 comfort positions with 2 seat depths. The backrest cushions and headrest are in polyurethane foam. The legs are available in painted metal with a bronze effect or painted in matt anthracite with a soft touch finish.

Divano modulare con struttura in metallo, con supporto di nastri elastici. Il materassino di seduta poggia su uno strato di poliuretano espanso a 3 densità ed è formato da un doppio strato di falda trapuntata con anima in gomma indeformabile. I braccioli sono in legno rivestiti in piuma d'oca anallergica ed in poliuretano. Gli schienali in legno sono dotati di un meccanismo che consente 2 posizioni di comfort con 2 profondità di seduta. I cuscini degli schienali ed i poggiatesta sono in poliuretano espanso. I piedi sono disponibili in metallo verniciato effetto bronzo o verniciati antracite opaco finizione Soft touch.

seat height

altezza seduta
43 cm
16.9"

seat depth

profondità seduta
57/81 cm
22.4/31.9"

arm width

larghezza braccio
24 cm
9.4"

arm height

altezza braccio
57 cm
22.4"

feet height

altezza piede
14 cm
5.5"

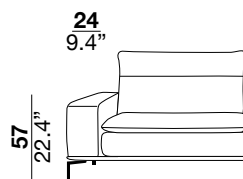
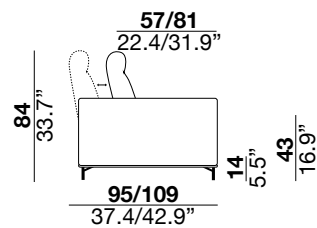

2

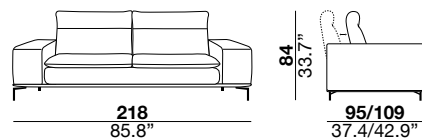

3

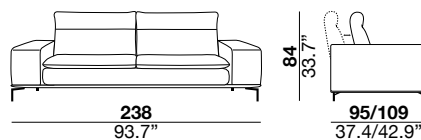

X

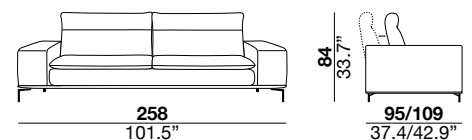

40

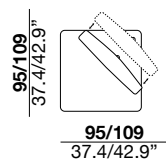

01

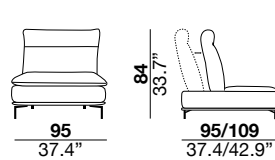

03

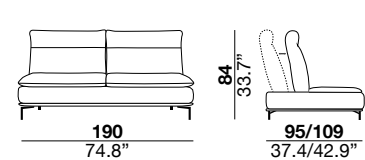

07/08

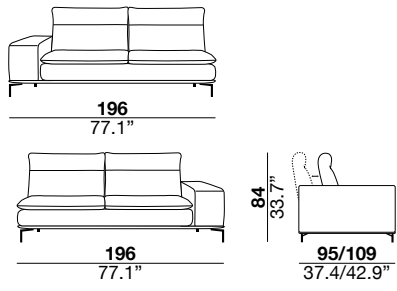

19/20

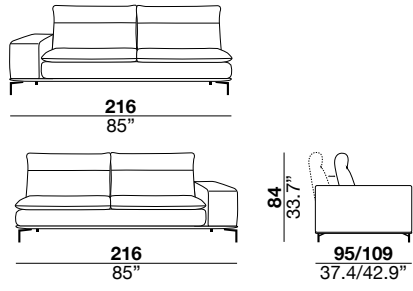

29/30

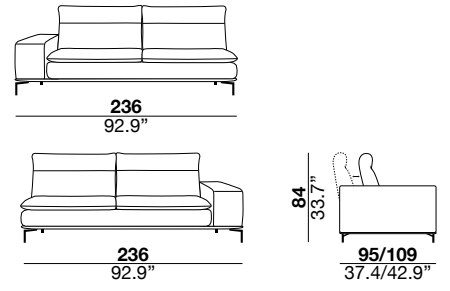

37/38

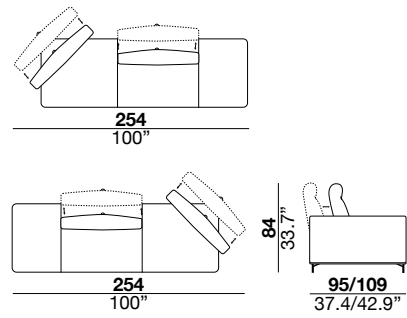

17/18

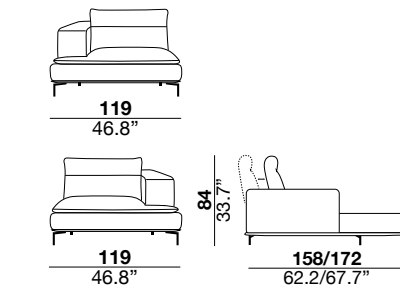

75/76

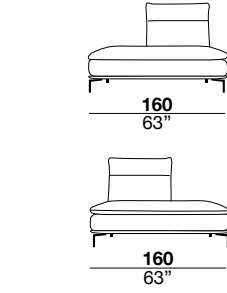

PRT

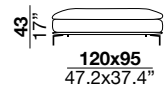

PQU

