

Progetto 1

TABLES

2006

Monica Armani



Description

Progetto 1 is a collection of tables with a pure and rigorous design intended to furnish refined workstations, executive offices and meeting rooms. Available in different sizes, they stand out for their attention to detail and the wide range of possible configurations. They have chromed steel structures to combine with wood or glass tops and can be equipped with shelves and cable holders. To complete the range, a chest of drawers with wheels.

Technical information

Top

veneered wood particles panel or glass

Frame

drawn steel

Internal frame

drawn steel and steel sheet

Shelf with supports

drawn steel and steel sheet

Horizontal and vertical cable grommet

steel sheet

Square and rectangular cable grommet

steel sheet with lid in stainless steel

Vertebra cable holder

thermoplastic material

Ferrules

steel sheet, thermoplastic material

Adjustable ferrules

steel and thermoplastic material

Technical drawings

P1T0808C

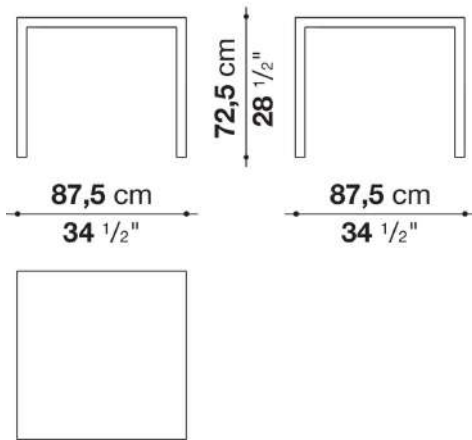

P1T0808C

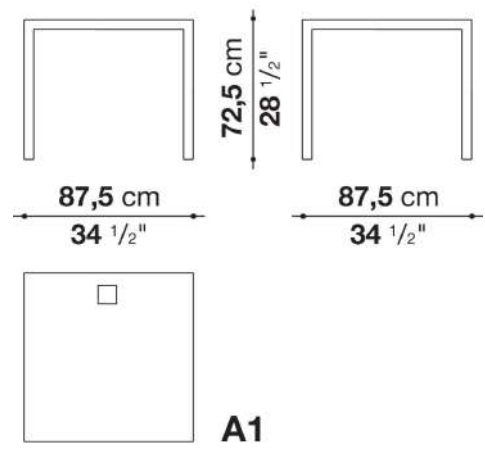

P1T1006C

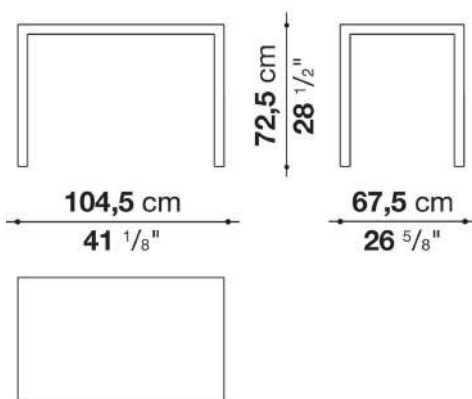

P1T1006C

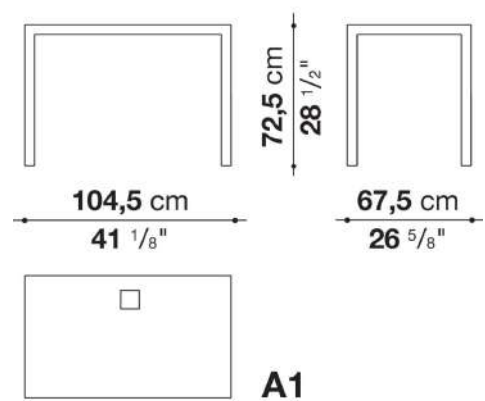

P1T1010C

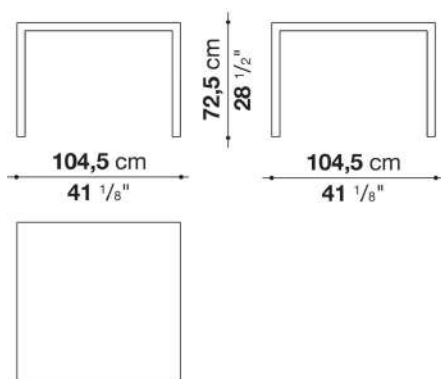

P1T1010C

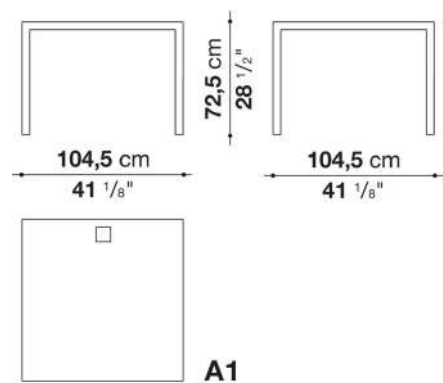

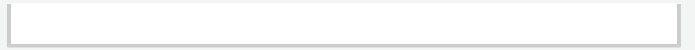
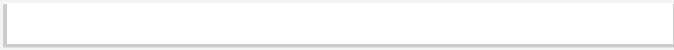

P1T1508C

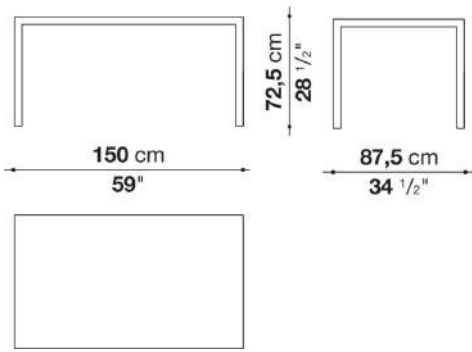

P1T1508C

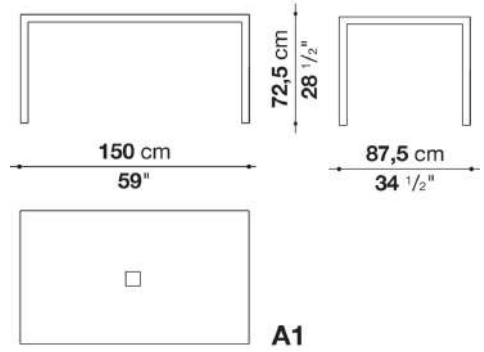

P1T1508C

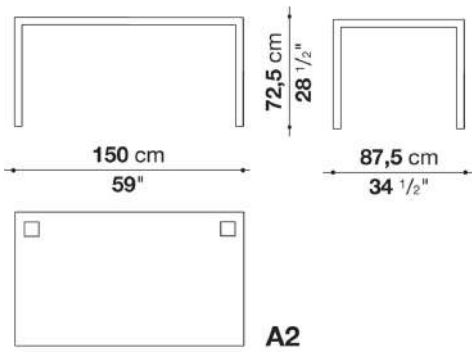

P1T1508C

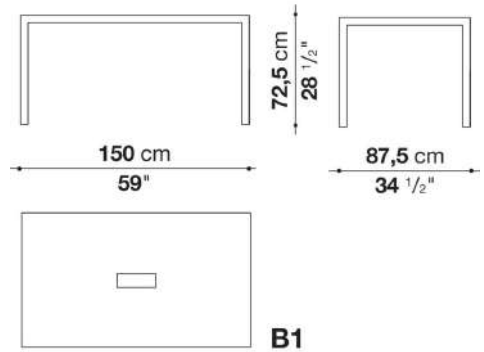

P1T1515C

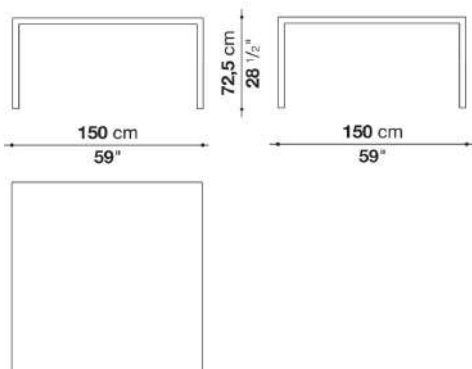

P1T1515C

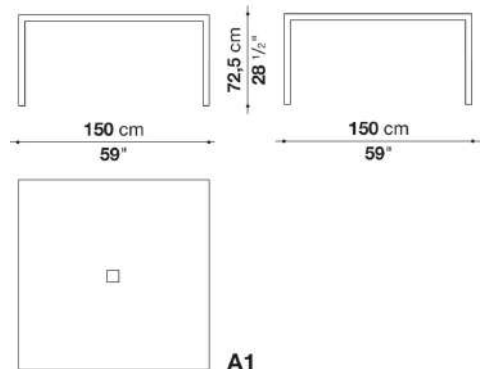

P1T1515C

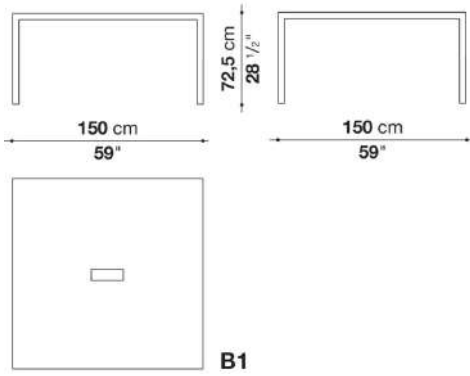

P1T1706C

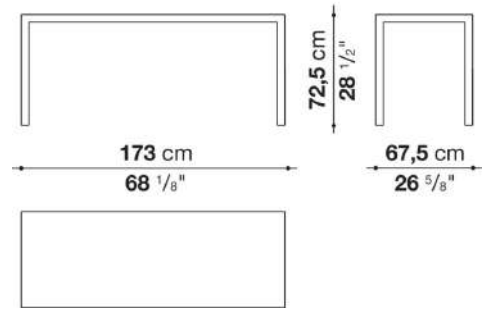

P1T1706C

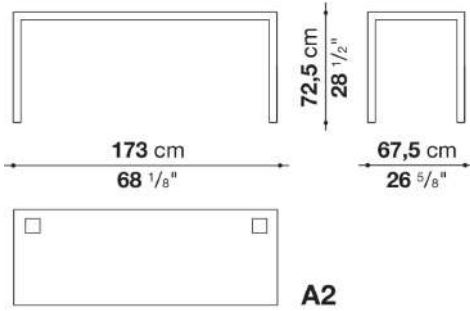

P1T1706C

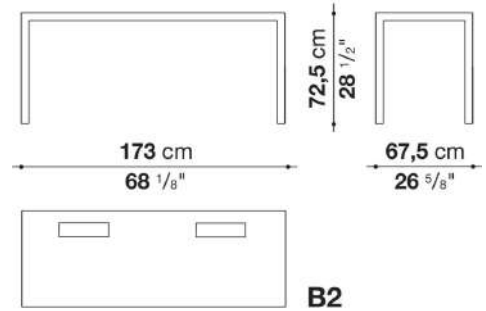

P1T1708C

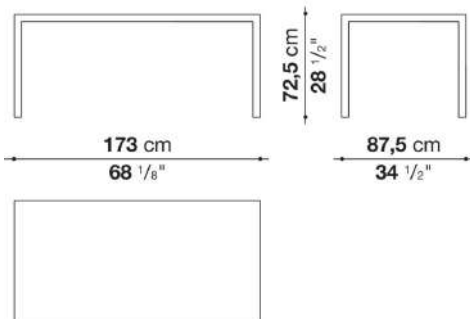

P1T1708C

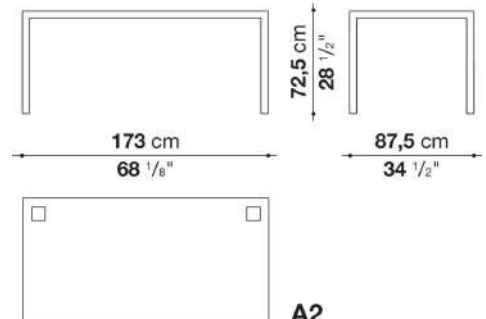

P1T1708C

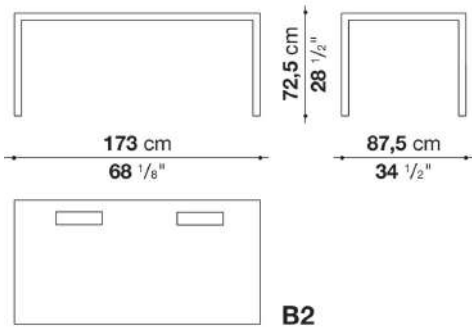

P1T1710C

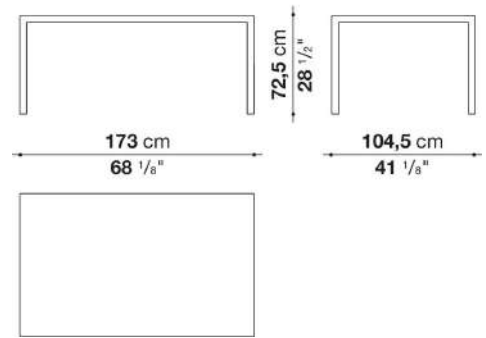

P1T1710C

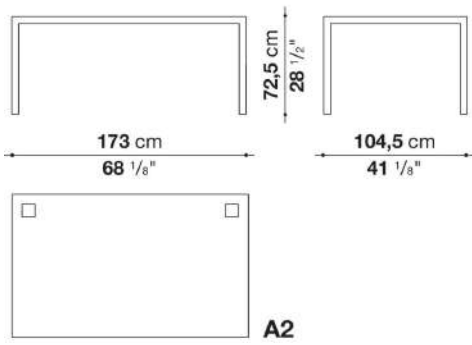

P1T1717C

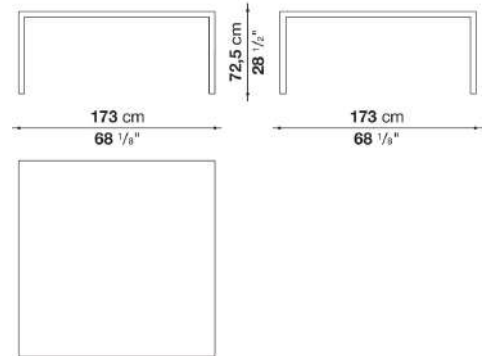

P1T1717C

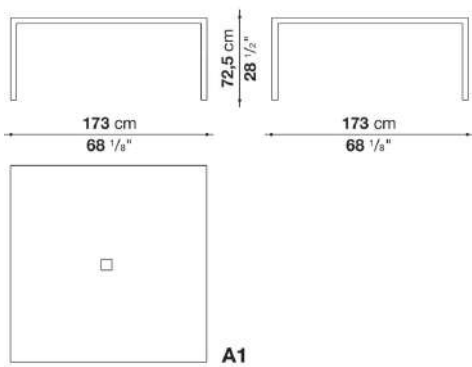

P1T1717C

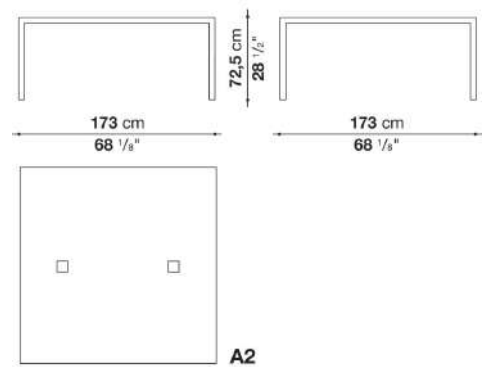

P1T1717C

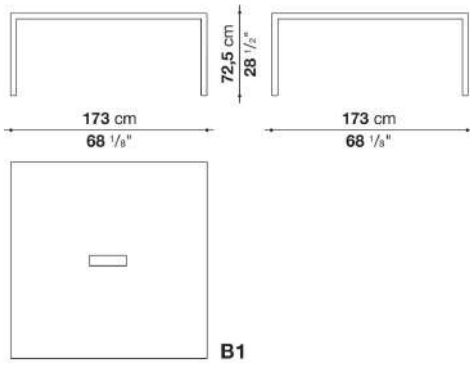

P1T1717C

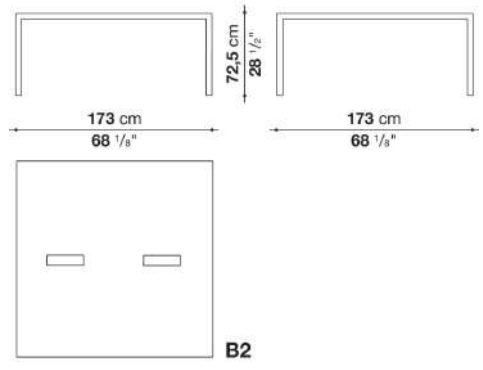

P1T2008C

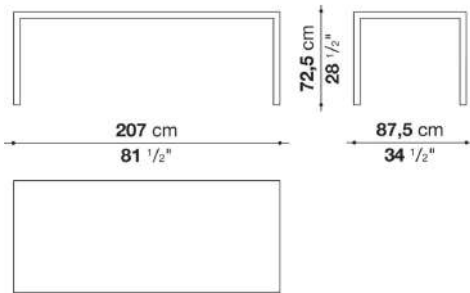

P1T2008C

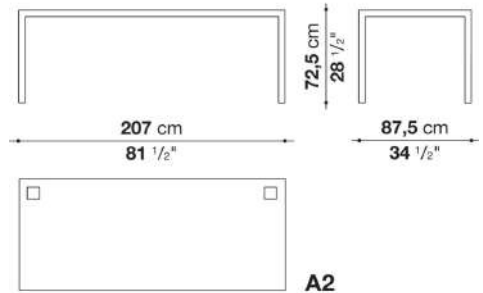

P1T2008C

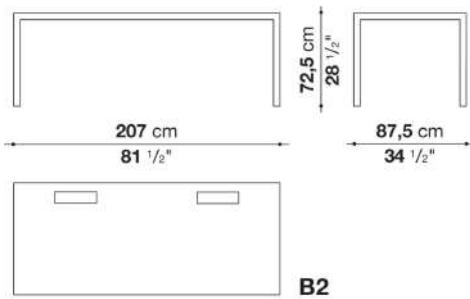

P1T2010C

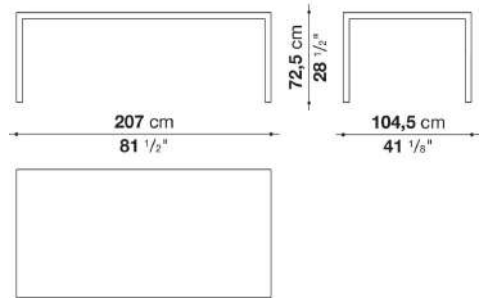

P1T2010C

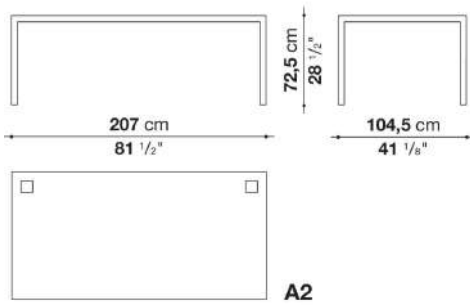

P1T2010C

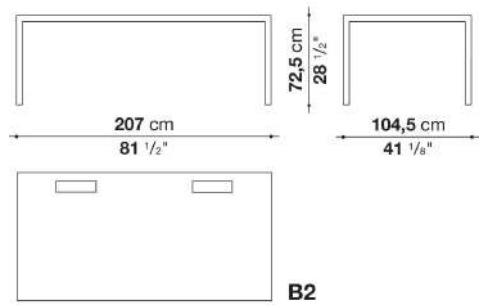

P1T2506C

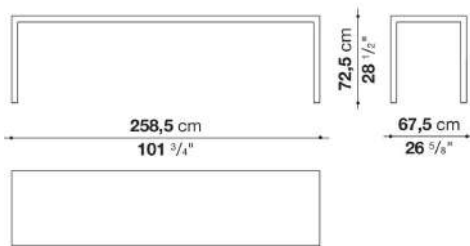

P1T2506C

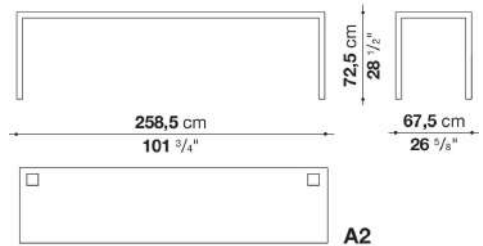

P1T2506C

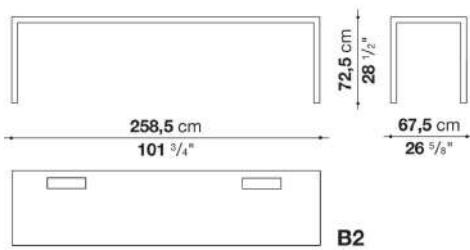

P1T2508C

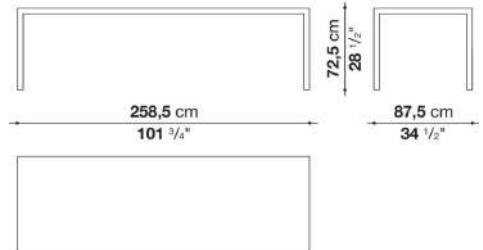

P1T2508C

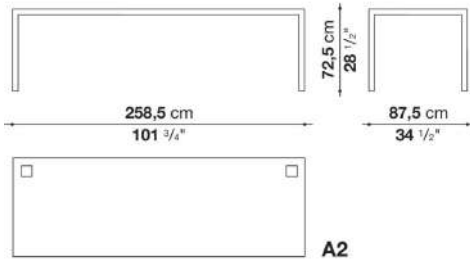

P1T2508C

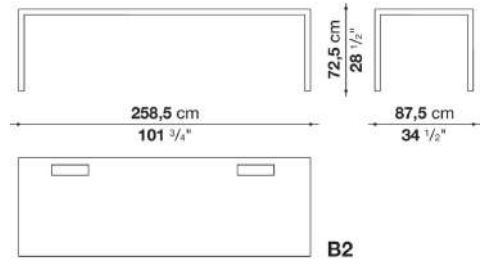

P1T2510C

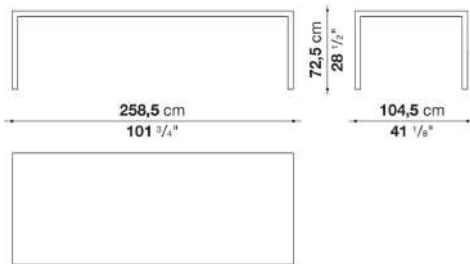

P1T2510C

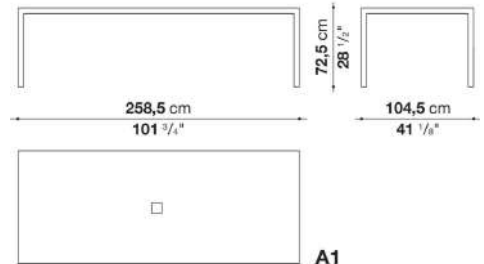

P1T2510C

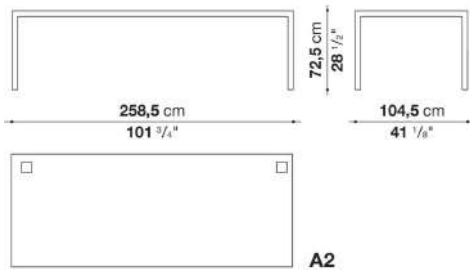

P1T2510C

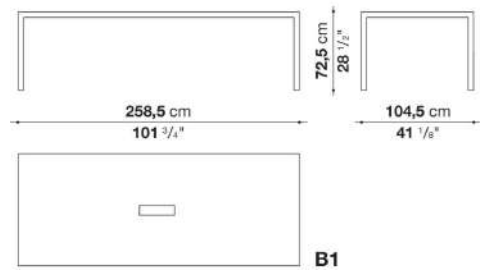

P1T2515C

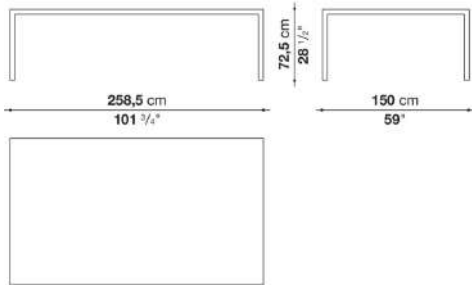

P1T2515C

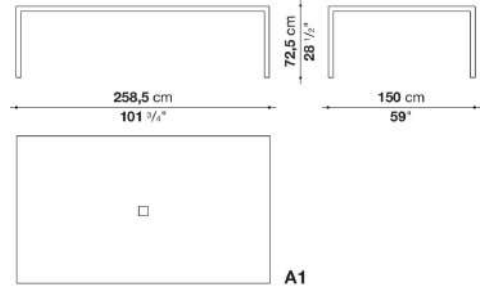

P1T2515C

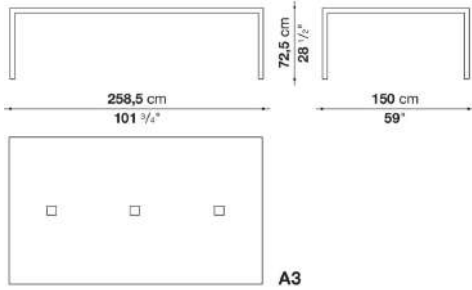

P1T2515C

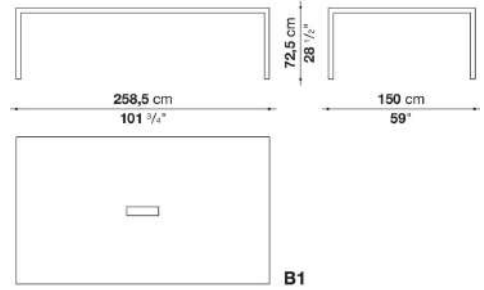

P1T2515C

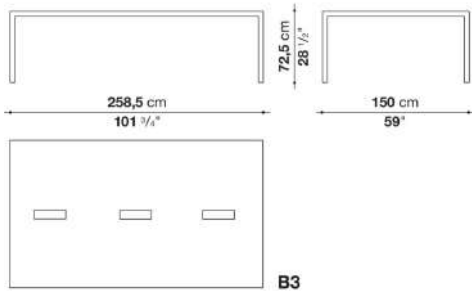

P1T2517C

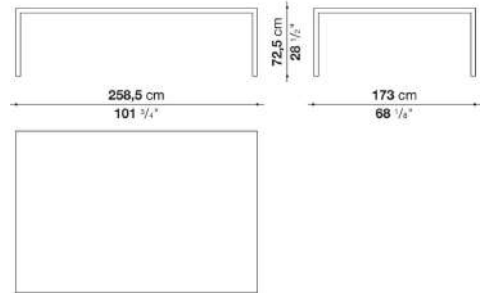

P1T2517C

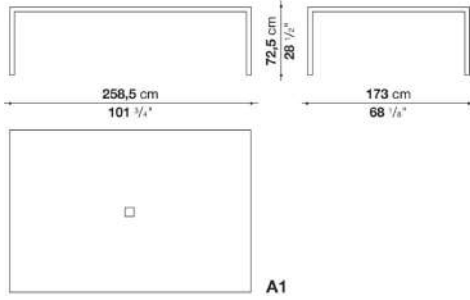

P1T2517C

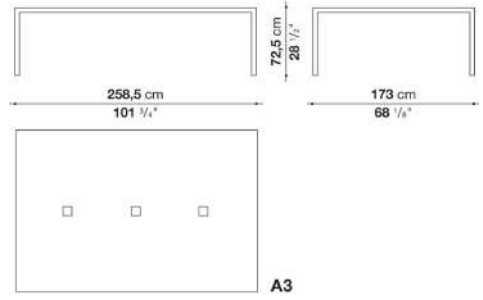

P1T2517C

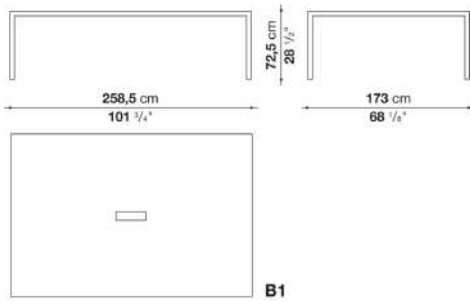

P1T2517C

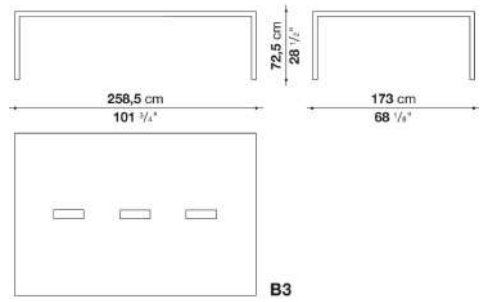

P1S0506A

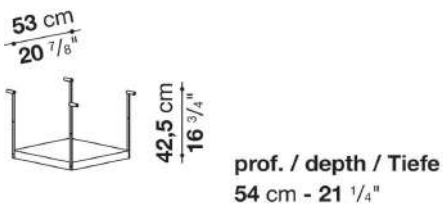

P1S0506AS

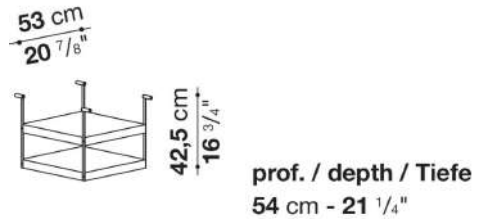

P1S0506B

53 cm
20 7/8"



prof. / depth / Tiefe
54 cm - 21 1/4"

P1S0508A

53 cm
20 7/8"



prof. / depth / Tiefe
74 cm - 29 1/8"

P1S0508AS

53 cm
20 7/8"



prof. / depth / Tiefe
74 cm - 29 1/8"

P1S0508B

53 cm
20 7/8"



prof. / depth / Tiefe
74 cm - 29 1/8"

P1S0510A

53 cm
20 7/8"



prof. / depth / Tiefe
94 cm - 37"

P1S0510AS

53 cm
20 7/8"



prof. / depth / Tiefe
94 cm - 37"

P1S0510B

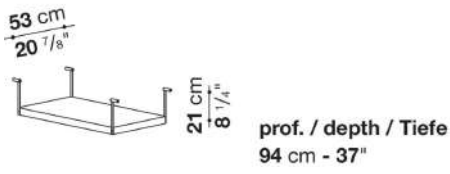

P1S1706A

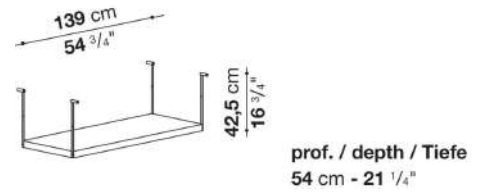

P1S1706AS

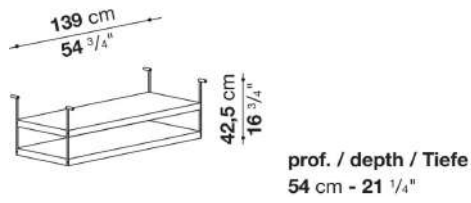

P1S1706B

