

FLEXFORM



MAGNUM *DESIGN CENTER* **2003**

SOFAS

FLEXFORM Spa

Via Einaudi 23/25 20821 Meda (MB) Italy | Tel. +39 0362 3991 | info@flexform.it | www.flexform.it

MAGNUM | *DESIGN CENTER* | 2003

Structure in solid wood with polyurethane foam padding, covered with a protective laminated fabric

Seat cushions in sterilized goose down (Assopiuma certified, gold label) with insert in crushproof material, or in polyurethane foam and dacron

Articles: 11UA1-11UA2-11UB3-11UB5-11UB7-11UB9-11UC3-11UC7-02D1A1-02D1A2-02D1B3-02D1B5-02D1B7-02D1B9-02D1C3-02D1C7 with padding in polyurethane foam and dacron

Backrest cushions in sterilized goose down (Assopiuma certified, gold label) and fiber

Optional cushions in sterilized goose down (Assopiuma certified, gold label). Optional cushions are upon request, with upcharge

Feet made of glossy transparent methacrylate

Base 24 in metal in satin, chrome, black chrome, burnished, glossy anthracite or matt titanium 710 finish

Upholstery removable fabric or not removable leather covers

COD. 011U42

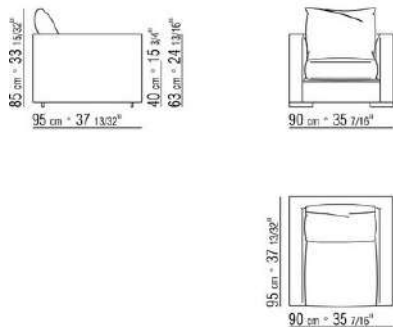

COD. 011U48

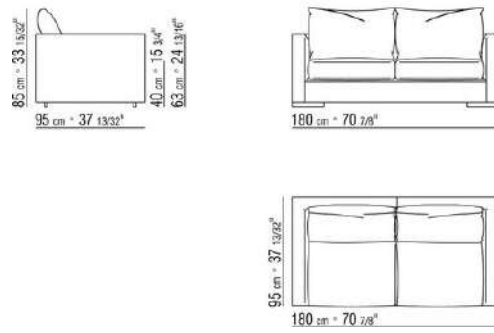

COD. 011U43

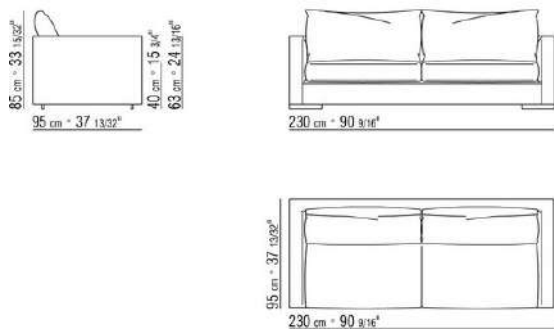

COD. 011U44

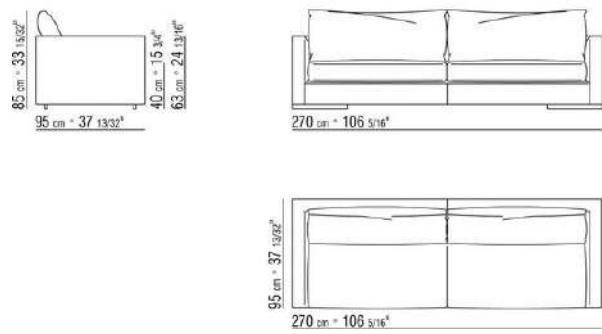

COD. 011U21

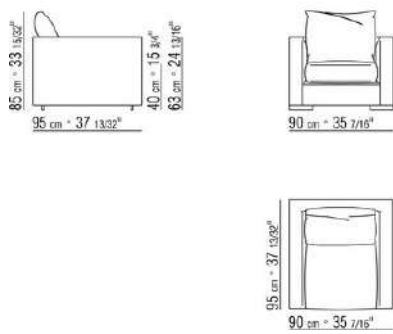

COD. 011U28

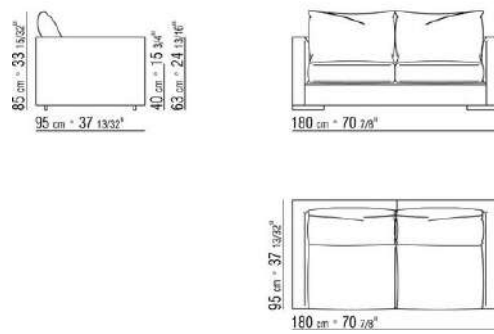

COD. 011U23

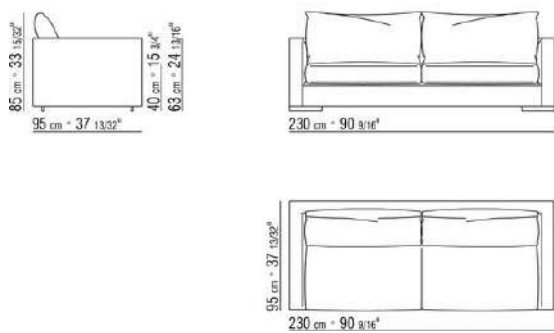

COD. 011U24

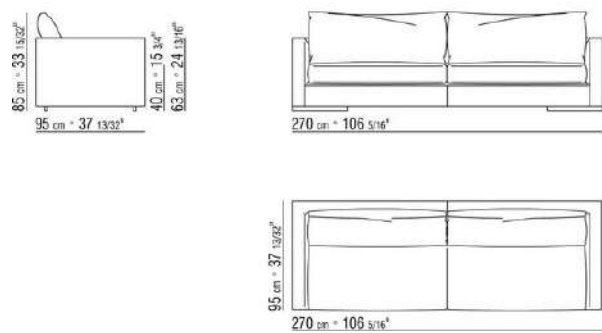

COD. 011U51

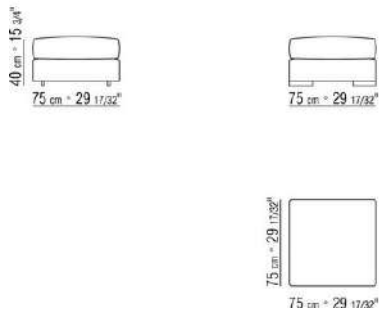

COD. 011U61

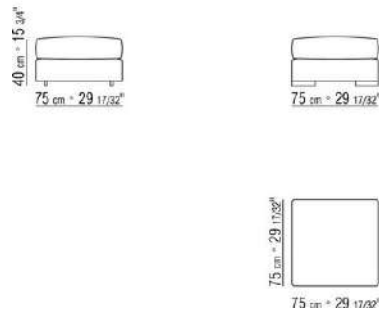

COD. 011U52

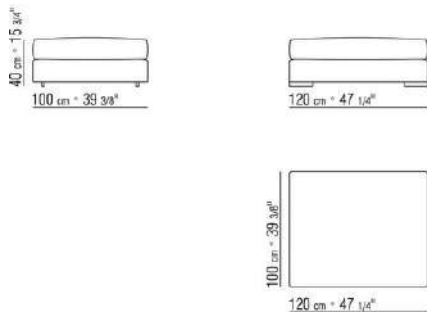

COD. 011U62

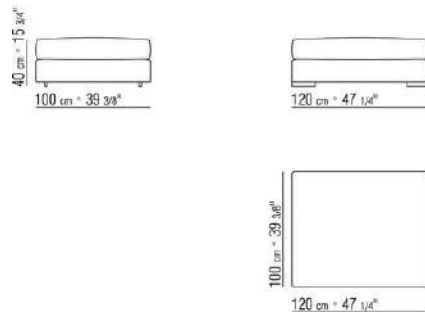

COD. 011U08

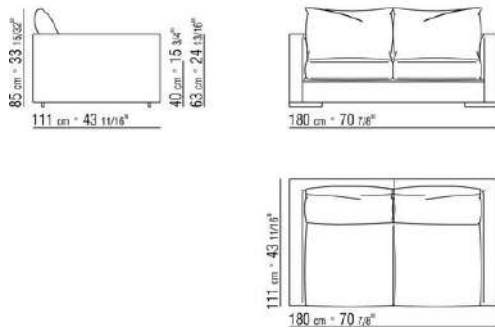

COD. 011U03

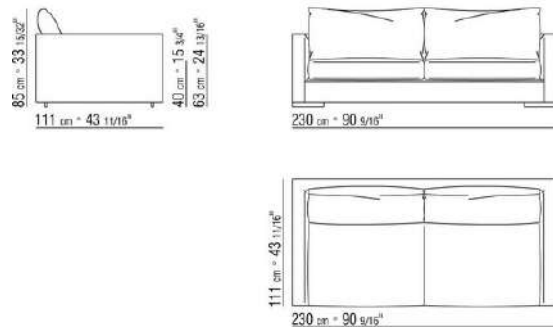

COD. 011U04

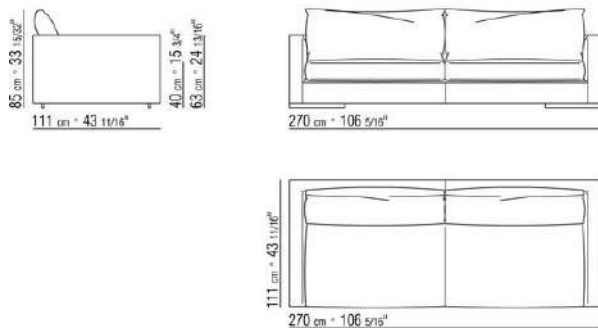

COD. 011U11

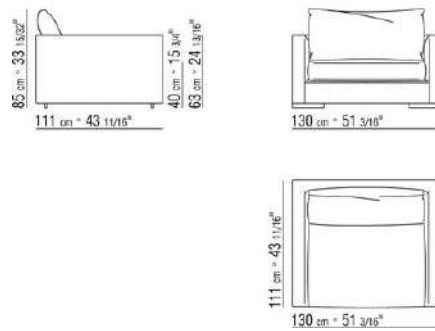

COD. 011U18

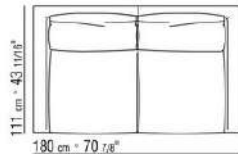
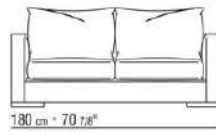
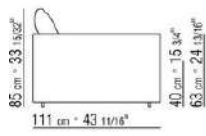

COD. 011U13

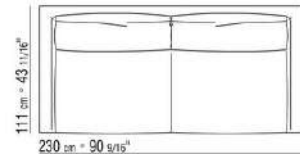
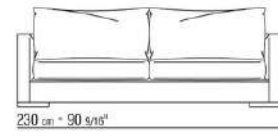
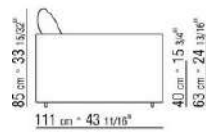

COD. 011U14

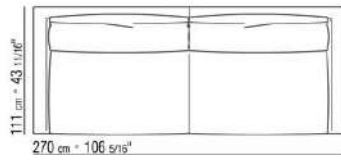
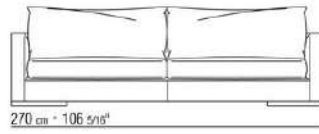
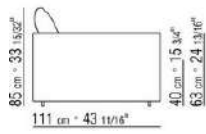

COD. 011U71

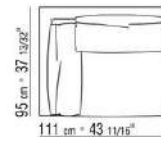
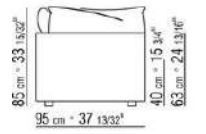

COD. 011U73

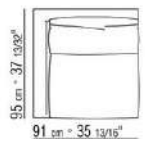
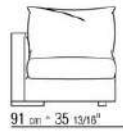
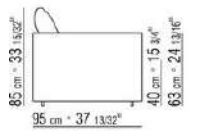

COD. 011U75

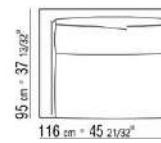
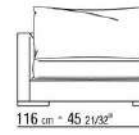

COD. 011U77

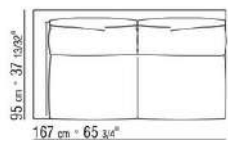
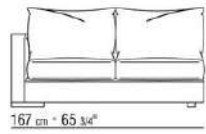
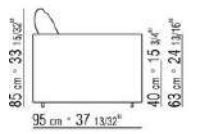

COD. 011U79

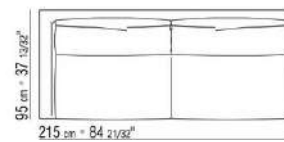
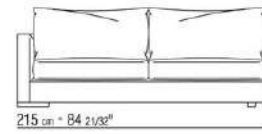
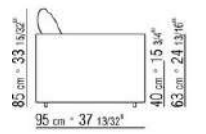

COD. 011U81

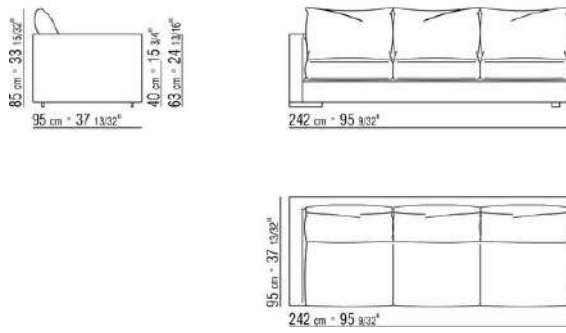

COD. 011U83

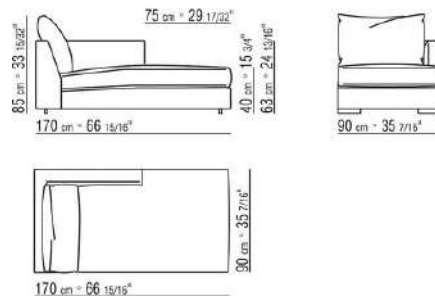

COD. 011U85

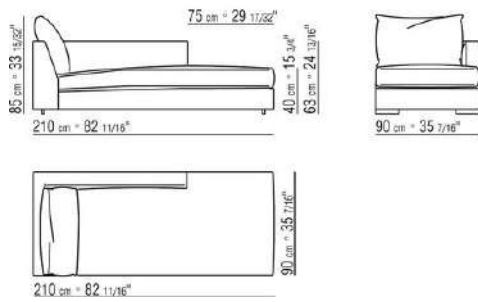

COD. 011U31

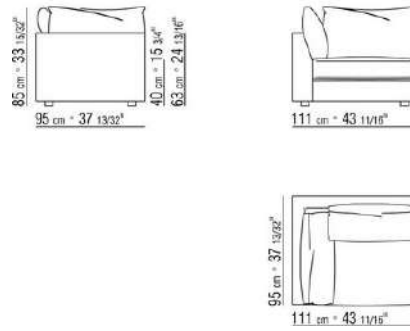

COD. 011U33

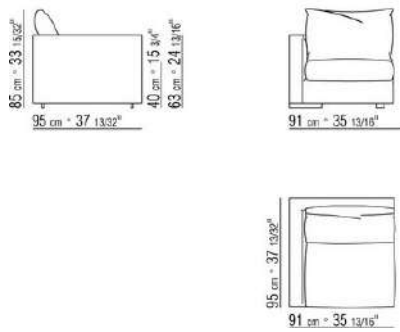

COD. 011U35

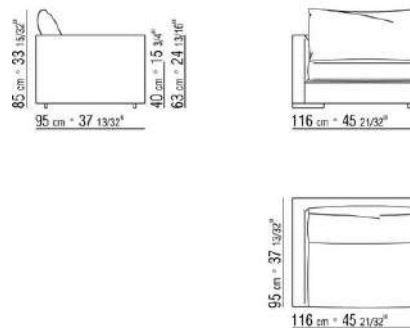

COD. 011U37

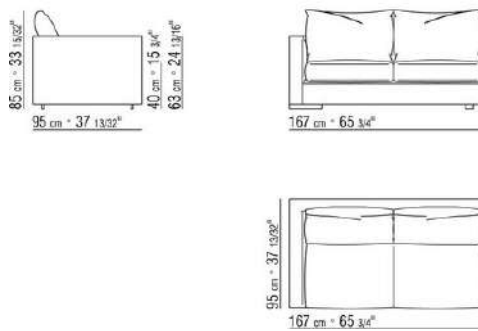

COD. 011U39

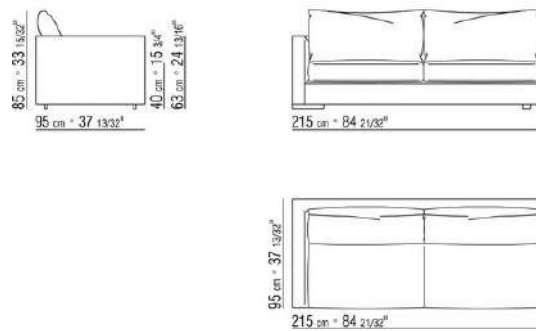

COD. 011U41

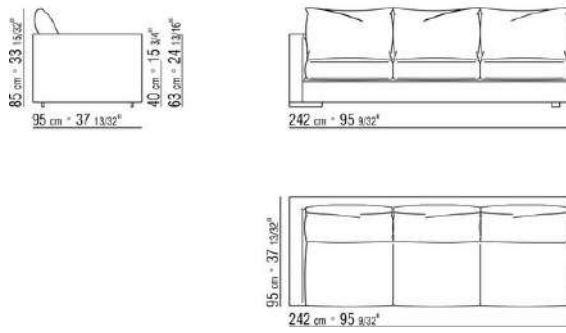

COD. 011U65

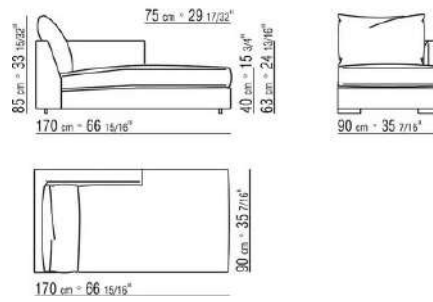

COD. 011U67

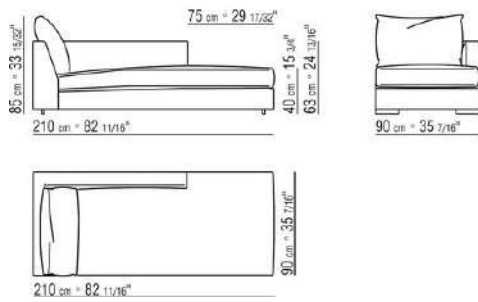

COD. 011UA1

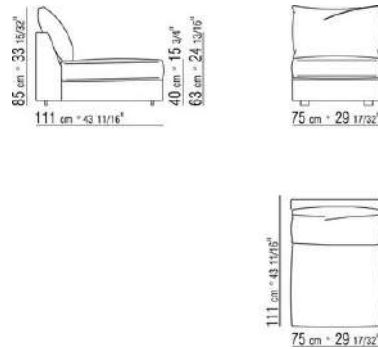

COD. 011UA2

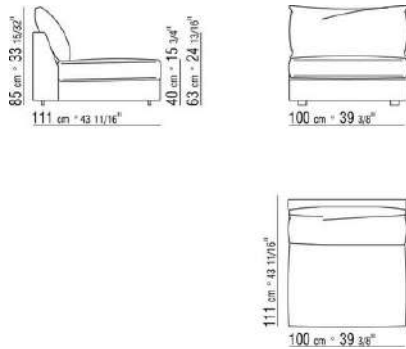

COD. 011UB3

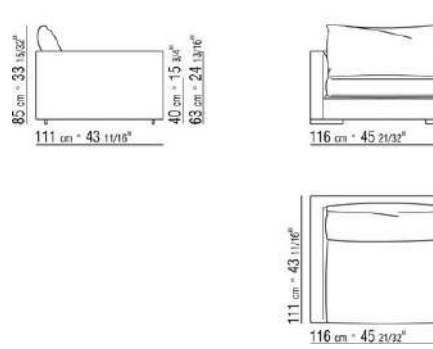

COD. 011UB5

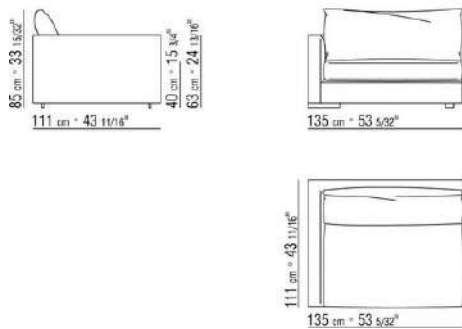

COD. 011UB7

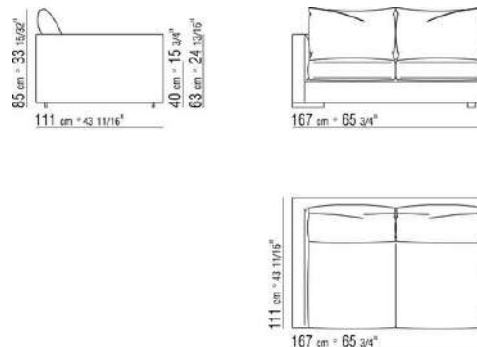

COD. 011UB9

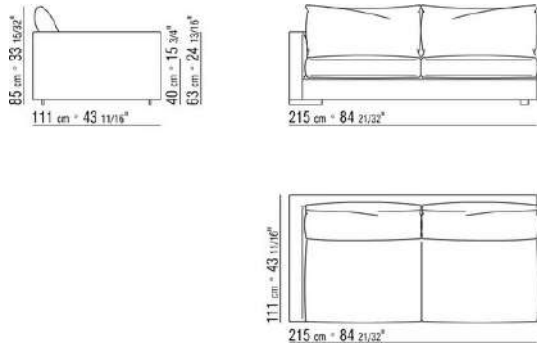

COD. 011UC3

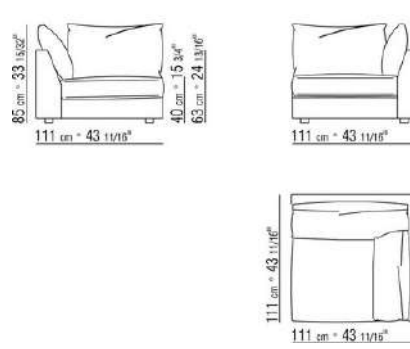

COD. 011UC7

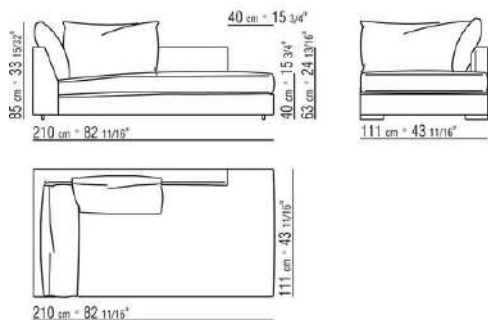

COD. 011U96

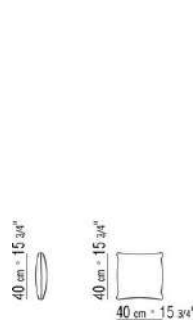

COD. 011U97

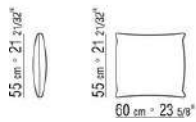

COD. 02D103

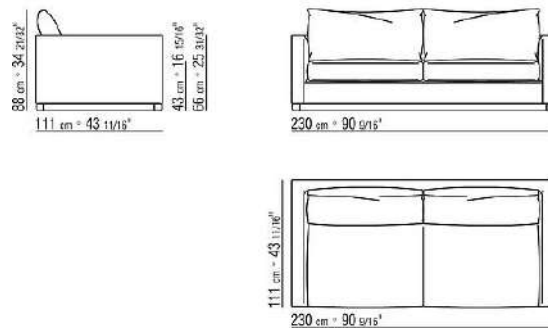

COD. 02D104

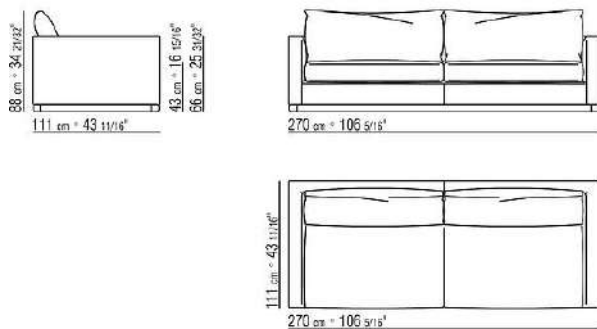

COD. 02D108

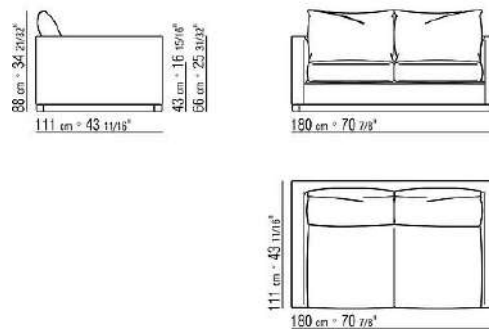

COD. 02D113

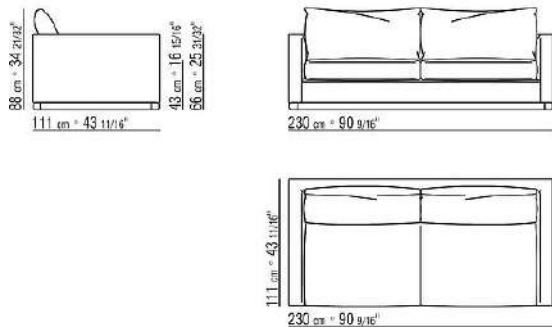

COD. 02D114

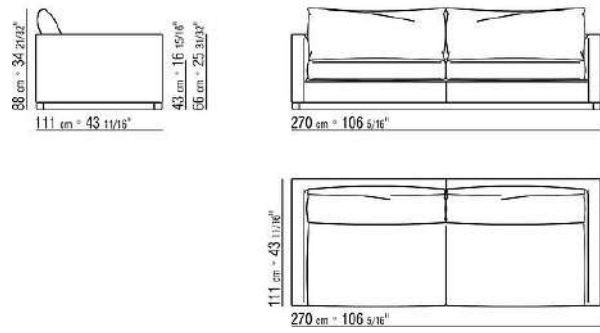

COD. 02D118

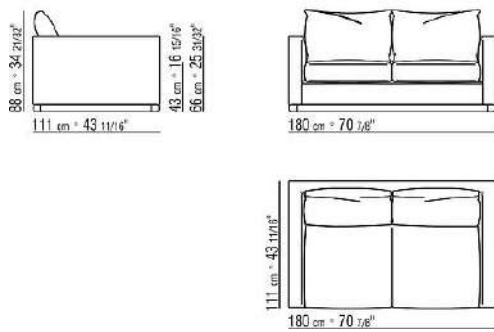

COD. 02D121

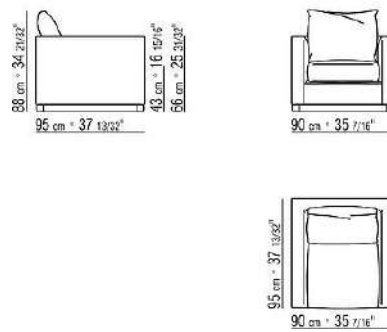

COD. 02D123

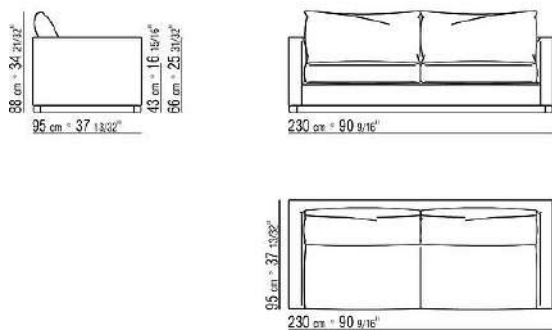

COD. 02D124

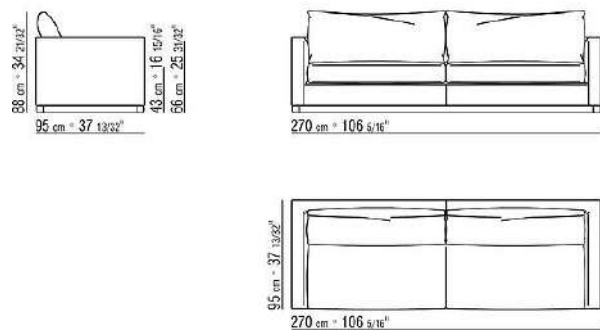

COD. 02D128

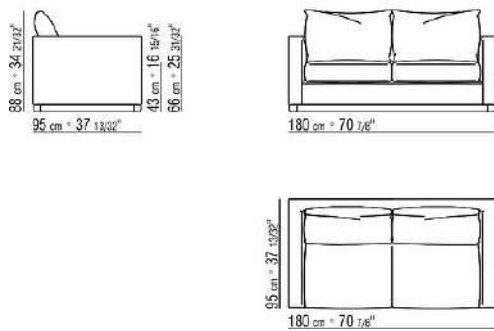

COD. 02D131

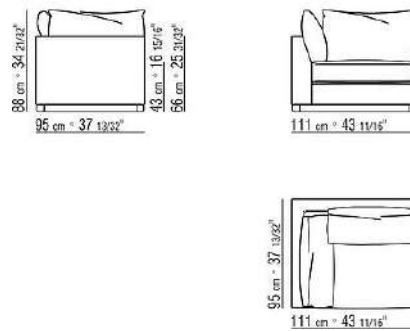

COD. 02D133

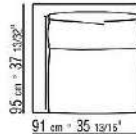
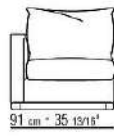
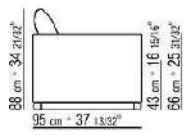

COD. 02D135

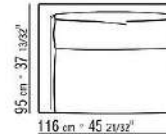
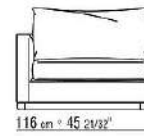
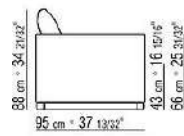

COD. 02D137

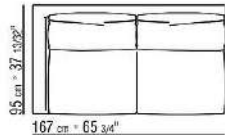
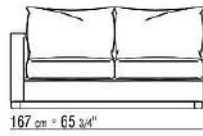
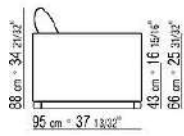

COD. 02D139

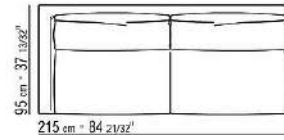
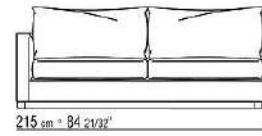
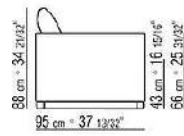

COD. 02D141

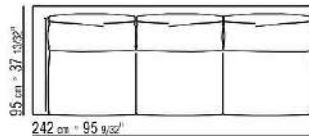
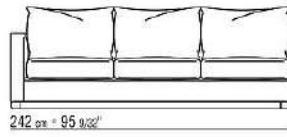
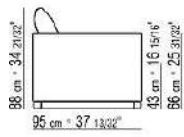

COD. 02D142

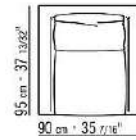
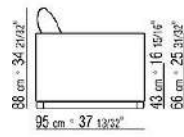

COD. 02D143

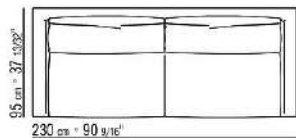
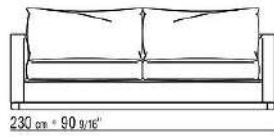
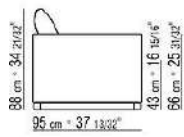

COD. 02D144

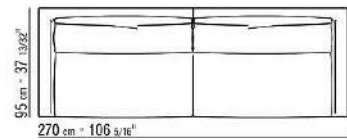
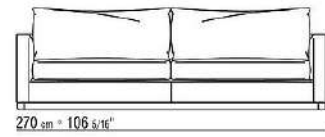
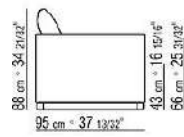

COD. 02D148

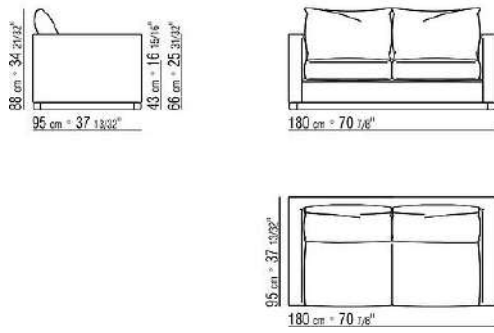

COD. 02D151

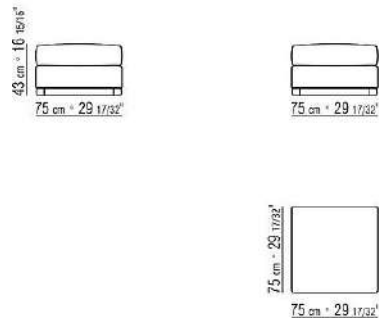

COD. 02D152

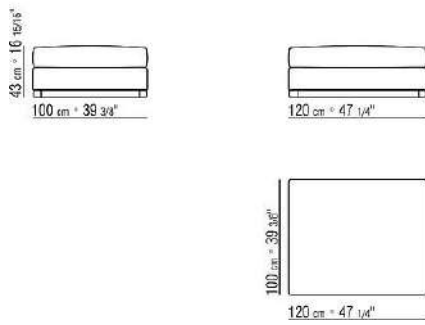

COD. 02D161

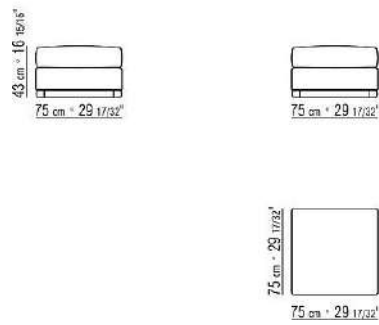

COD. 02D162

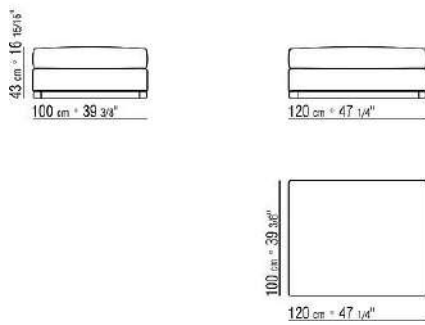

COD. 02D165

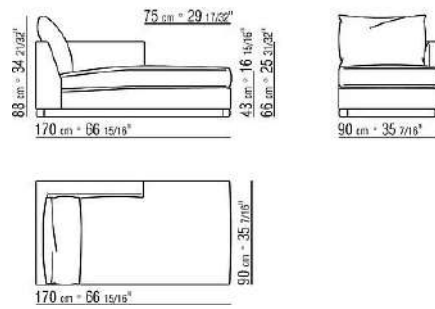

COD. 02D167

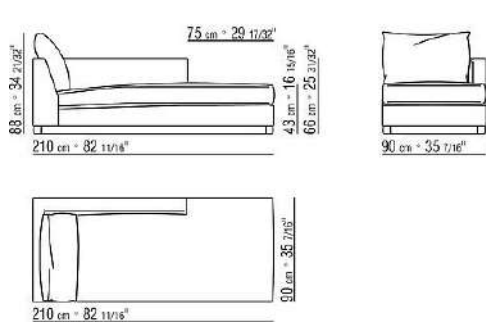

COD. 02D171

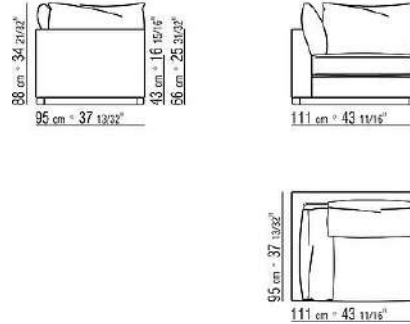

COD. 02D173

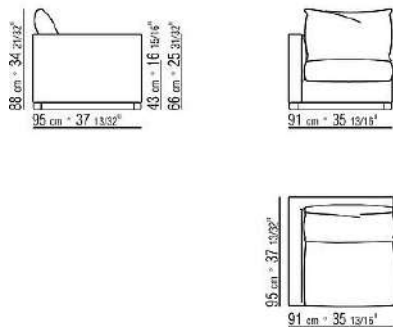

COD. 02D175

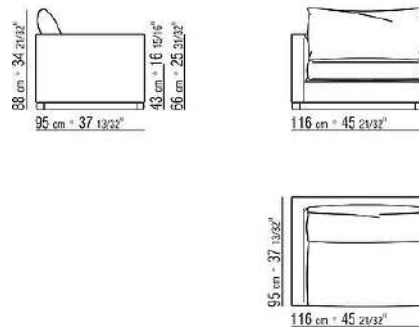

COD. 02D177

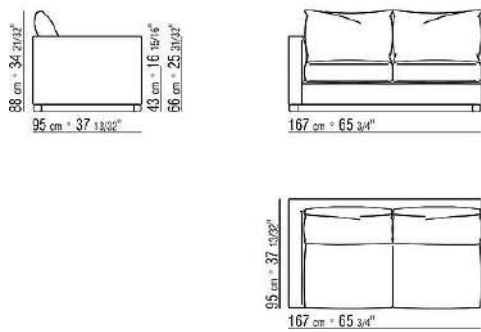

COD. 02D179

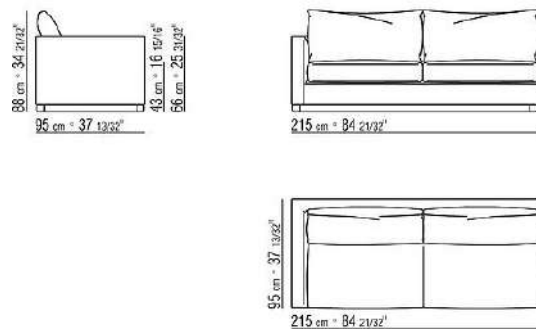

COD. 02D181

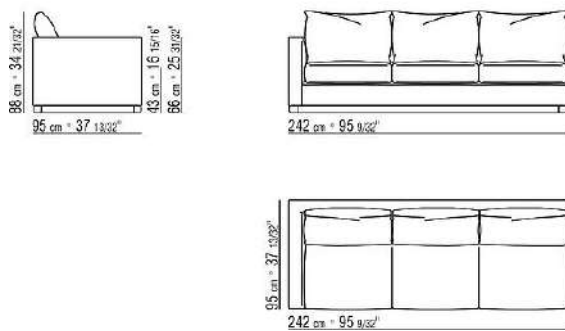

COD. 02D183

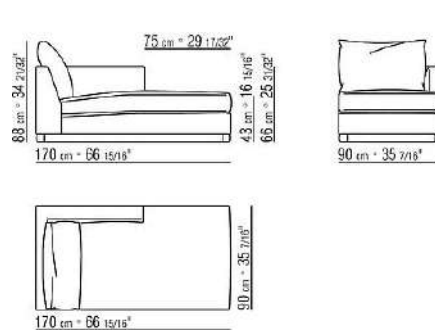

COD. 02D185

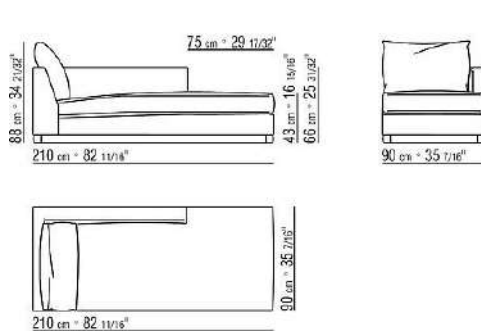

COD. 02D1A1

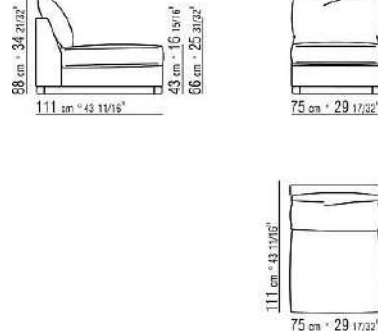

COD. 02D1A2

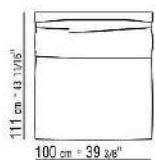
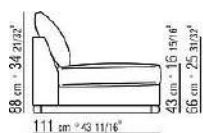

COD. 02D1B3

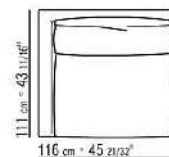
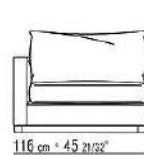
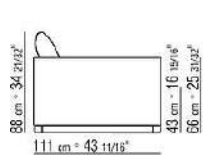

COD. 02D1B5

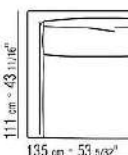
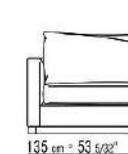

COD. 02D1B7

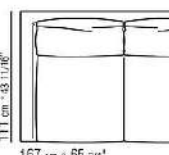
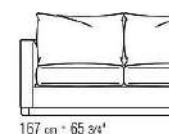
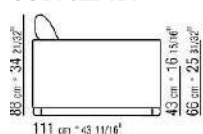

COD. 02D1B9

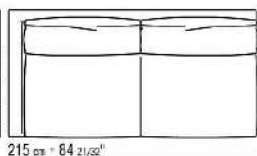
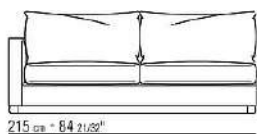
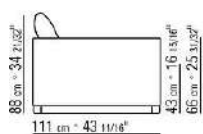

COD. 02D1C3

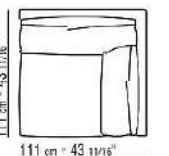

COD. 02D1C7

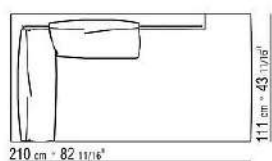
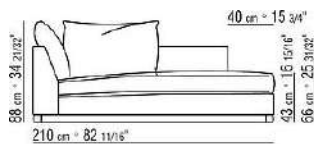

011UXA

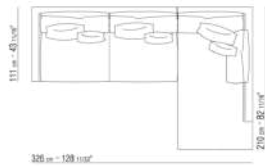

- N.1 COD.011UB9 - END UNIT L / DACRON CM.215 x111
- N.3 COD.011U96 - CUSHION CM.40 x40
- N.1 COD.011UC7 - LONG CORNER L /DACRON CM.111 x210
- N.3 COD.011U97 - CUSHION CM.60 x55

011UXB

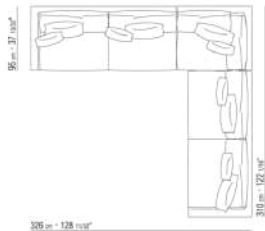

- N.1 COD.011U79 - END UNIT L CM.215 x95
- N.1 COD.011U78 - END UNIT R CM.215 x95
- N.1 COD.011U70 - CORNER R CM.111 x95
- N.5 COD.011U96 - CUSHION CM.40 x40
- N.5 COD.011U97 - CUSHION CM.60 x55