

Papilio

CHAIRS

2008

Naoto Fukasawa

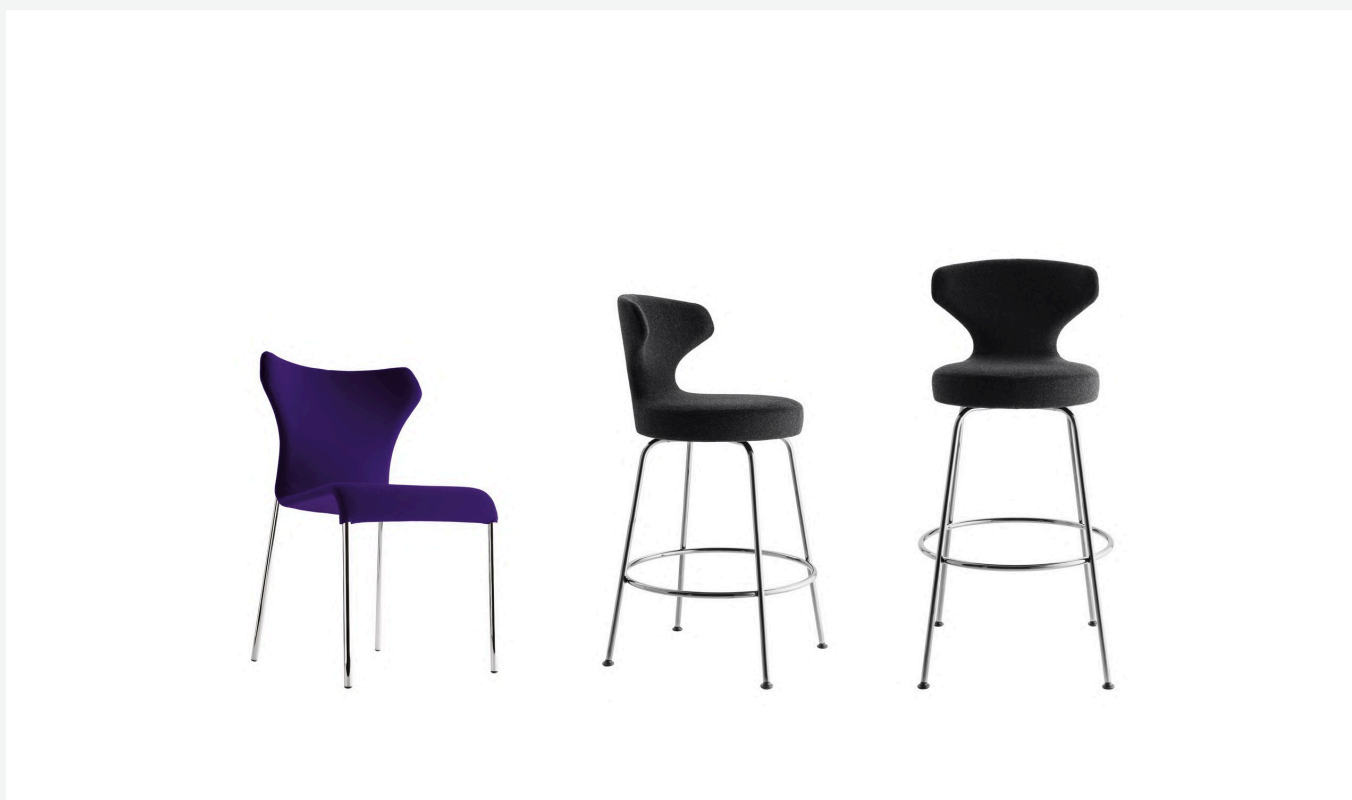

Description

A chair and stool in two heights, Papilio can be used in formal contexts, while also allowing for a more informal use by leaning on one of the back's "wings", inspired by those of a butterfly (or "Papilio" in Latin). The formal balance derives from the constant thickness of the shell and from the shape of the seat, which is sinuous in the upper part and then merges with the light steel frame. Upholstered in either leather or fabric, Papilio's cover can be removed using a metal zipper on the back, a functional and decorative detail that characterises the entire line of chairs of the same name.

Technical information

Internal frame

thermoplastic material shell

Internal frame upholstery

Bayfit® flexible cold shaped polyurethane foam, polyester fibre cover

Legs

tubular steel and steel profiles

Ferrules

thermoplastic material

Cover

fabric or leather in limited categories

Technical drawings

PA

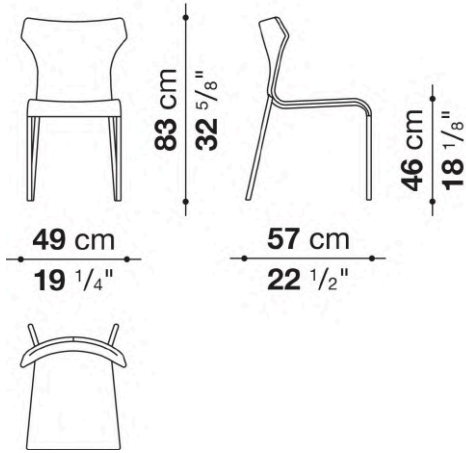

SP51B

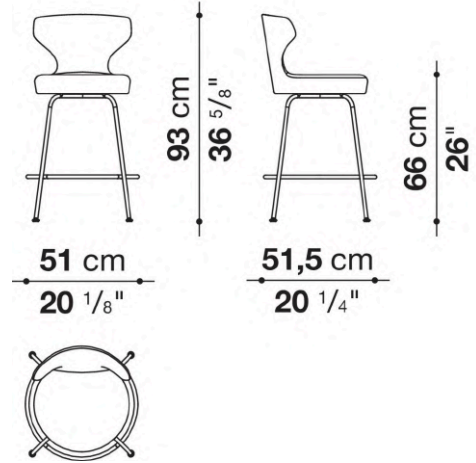

SP51A

