

Lilum

SOFAS

2023

Antonio Citterio



Description

Characterized by the sinuous, organic-inspired lines Lilum is designed specifically for convivial and intimate solutions, and therefore to exist within the same environment together with more formal sofas. This is the only sofa in the Maxalto range with a direct seating frame. It is available in various compact shapes. The construction technique is mixed: the backrest is molded using in-house technology that ensures maximum precision of each profile, while the base is made using the classic technique for quality with multilayer glued laminated wood, without nails or glue. The aluminium profile in various finishes, that perfectly follow its geometry that defines the contour with a touch of understated refinement, while the accentuated edge separating the base from the seating, is a reminder of traditional handcrafted sofas.

Technical information

Internal frame
tubular steel and steel profiles
Seat internal frame
multi-layered wood panel
Seat internal frame upholstery
shaped polyurethane of different density, polyester fibre cover
Back internal frame upholstery
Bayfit® flexible cold shaped polyurethane foam, polyester fibre cover
Cushion (LIL60C)
polyester fibre
Lower edge
aluminium extrusions
Ferrules
thermoplastic material
Cover
fabric or leather

Technical drawings

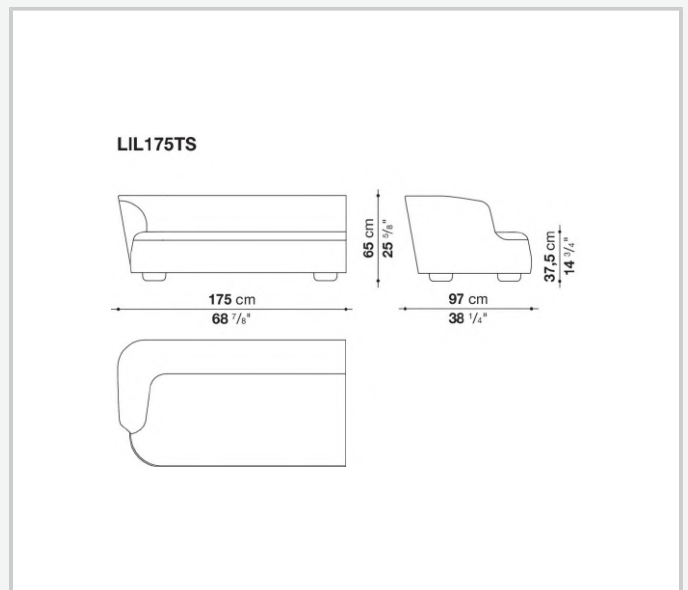
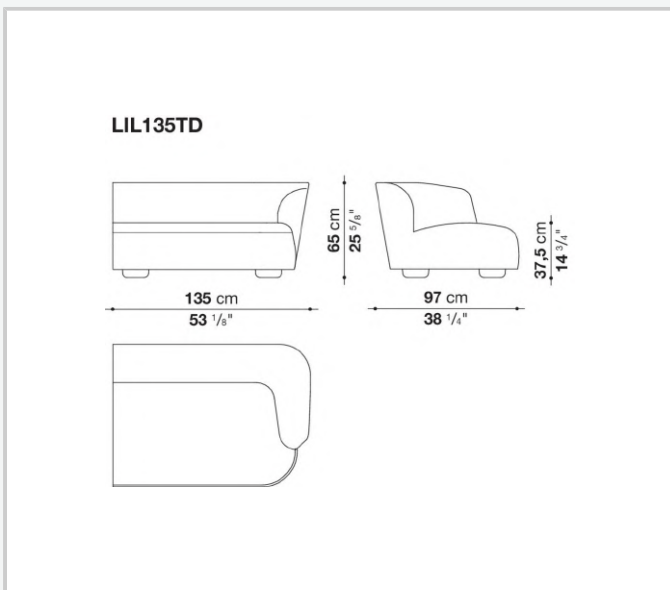
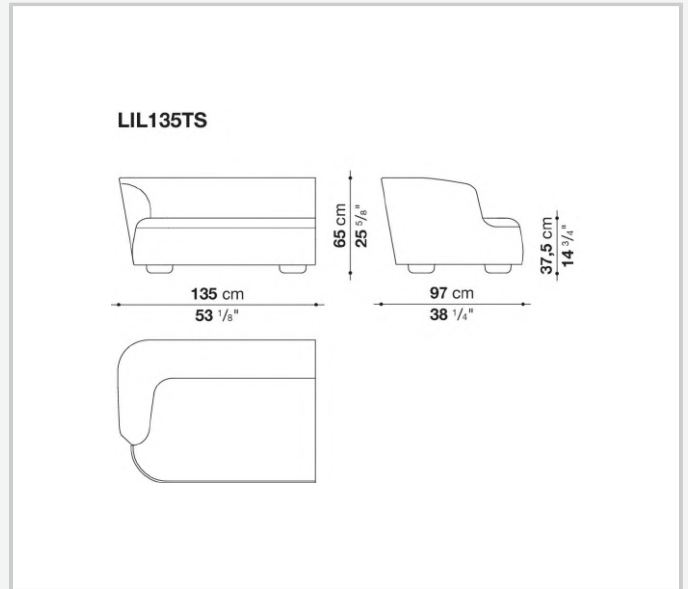
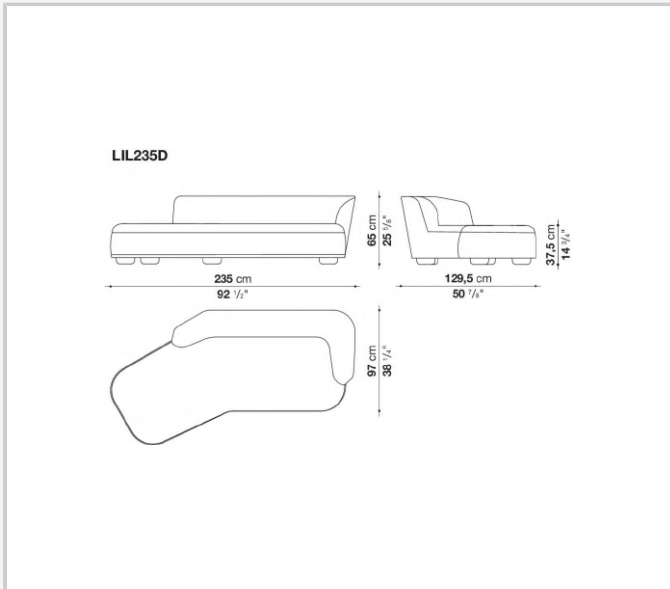
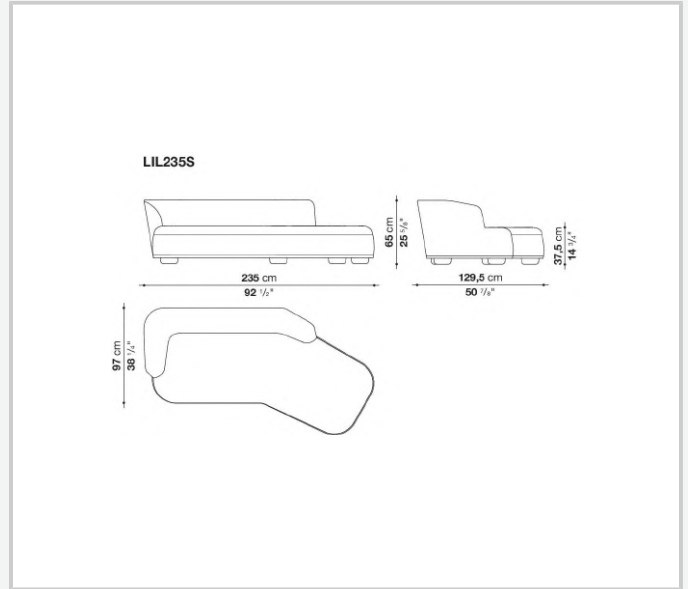
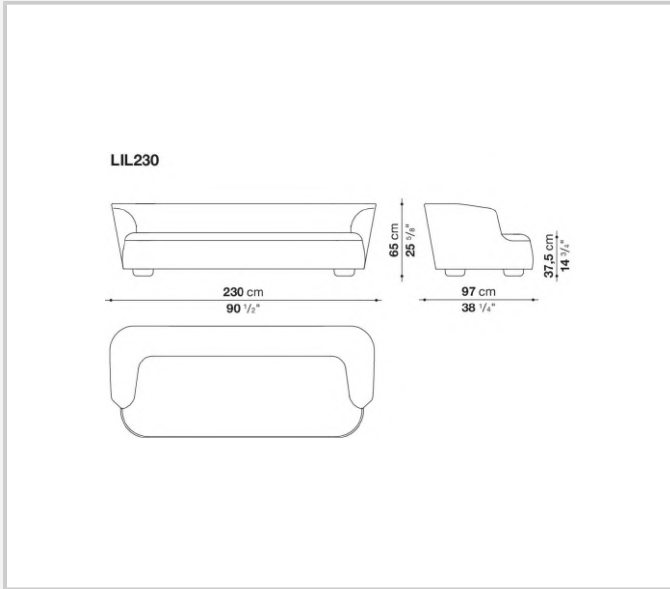

LIL175TD

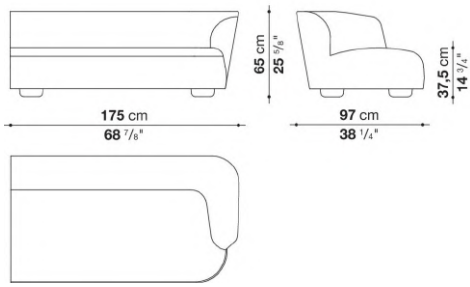

LIL240TS

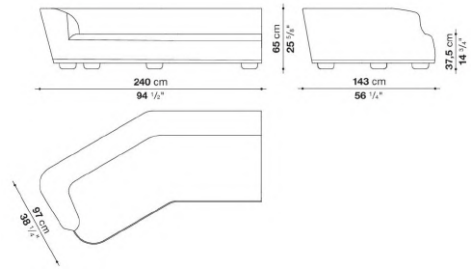

LIL240TD

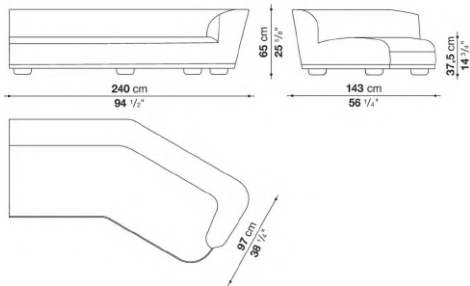

LIL155AS

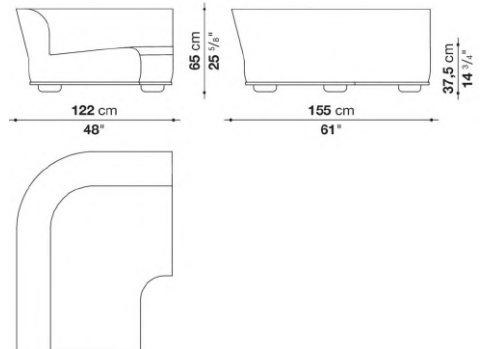

LIL155AD

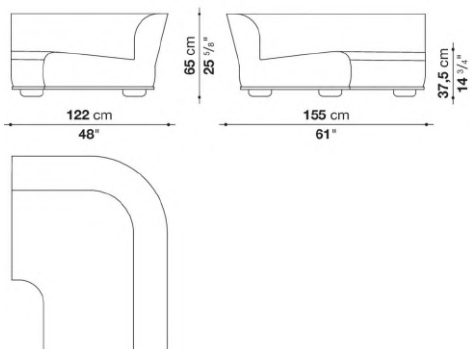

LIL175LS

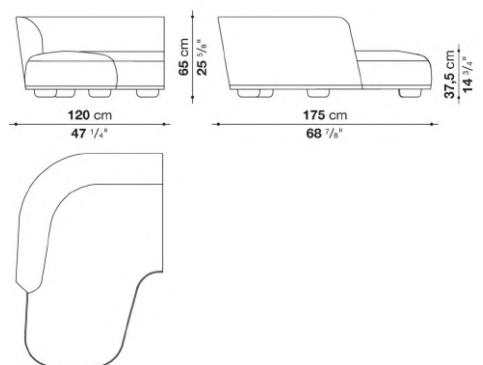

LIL175LD

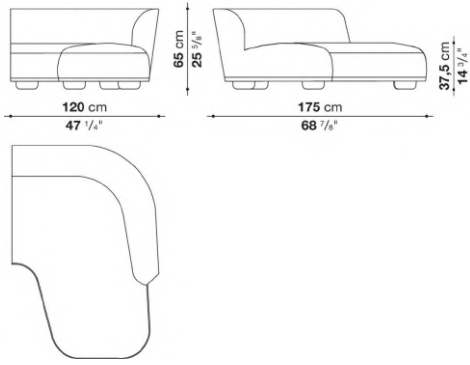

LIL225LS

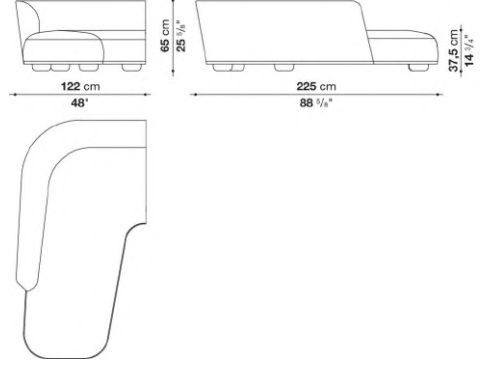

LIL225LD

